

Features

- 1600 LR Wall® is a low rise curtain wall system for stock length sales
- 1600 LR Wall® has a 2-1/2" (63.5) sightline
- Standard 5-3/4" (146.1) or 7-1/4" (184.2) depth systems
- This system is outside, pressure glazed available captured or SSG
- Captured system:
 - No drilled weeps
 - Water deflectors used typically
 - Intermediate horizontals are mullion drained
 - Joint plugs only required at weeped horizontals above vertical splices
- SSG system:
 - Structural silicone glazed verticals and captured horizontals
 - Extruded joint plugs required with weeped intermediate horizontals
- Infill options are 1/8" (3.2), 1/4" (6.4) or 1" (24.5)
- Concealed fastener joinery creates smooth, monolithic appearance
- EPDM gasket and thermal break
- Open back horizontals and perimeters are available for cost savings
- Shear block fabrication method
- Corner mullions available
- Offers integrated entrance framing systems
- Silicone compatible glazing materials for long-lasting seals
- Two color option
- Permanodic® anodized finishes option
- Painted finishes in standard and custom choices

Optional Features

- Steel reinforcing available
- Captured system heavy-weight mullion available for 7-1/4" (184.2) system
- Captured system integrates with standard Kawneer windows
- Integrates with standard Kawneer windows and GLASSvent® windows for storefront framing and curtainwall
- Profit\$Maker® Plus die sets available

Product Applications

- Ideal for low rise applications
 - 4 stories or less, no more than one splice per mullion

For specific product applications,
consult your Kawneer representative.

Laws and building and safety codes governing the design and use of Kawneer products, such as glazed entrance, window, and curtain wall products, vary widely. Kawneer does not control the selection of product configurations, operating hardware, or glazing materials, and assumes no responsibility therefor.

Kawneer reserves the right to change configuration without prior notice when deemed necessary for product improvement.
© 2013, Kawneer Company, Inc.

Architects - Most extrusion and window types illustrated in this catalog are standard products for Kawneer. These concepts have been expanded and modified to afford you design freedom. Some miscellaneous details are non-standard and are intended to demonstrate how the system can be modified to expand design flexibility. Please contact your Kawneer representative for further assistance.

PICTORIAL VIEW5

TYPICAL DETAILS6

ENTRANCE DETAILS7

CORNER DETAILS8, 9

**GLASSvent® WINDOWS FOR STOREFRONT AND
CURTAIN WALL10**

WINDOW APPLICATION11

ANCHOR DETAILS12, 13

WINDLOAD CHARTS14-20

DEADLOAD CHARTS21-23

THERMAL CHARTS24-32

Metric (SI) conversion figures are included throughout these details for reference. Numbers in parentheses () are millimeters unless otherwise noted.

The following metric (SI) units are found in these details:

- m – meter
- cm – centimeter
- mm – millimeter
- s – second
- Pa – pascal
- MPa – megapascal

Laws and building and safety codes governing the design and use of Kawneer products, such as glazed entrance, window, and curtain wall products, vary widely. Kawneer does not control the selection of product configurations, operating hardware, or glazing materials, and assumes no responsibility therefor.

Kawneer reserves the right to change configuration without prior notice when deemed necessary for product improvement.
© 2013, Kawneer Company, Inc.

Laws and building and safety codes governing the design and use of Kawneer products, such as glazed entrance, window, and curtain wall products, vary widely. Kawneer does not control the selection of product configurations, operating hardware, or glazing materials, and assumes no responsibility therefor.

Kawneer reserves the right to change configuration without prior notice when deemed necessary for product improvement.
© 2013, Kawneer Company, Inc.

Laws and building and safety codes governing the design and use of Kawneer products, such as glazed entrance, window, and curtain wall products, vary widely. Kawneer does not control the selection of product configurations, operating hardware, or glazing materials, and assumes no responsibility therefor.

Kawneer reserves the right to change configuration without prior notice when deemed necessary for product improvement.
© 2013, Kawneer Company, Inc.

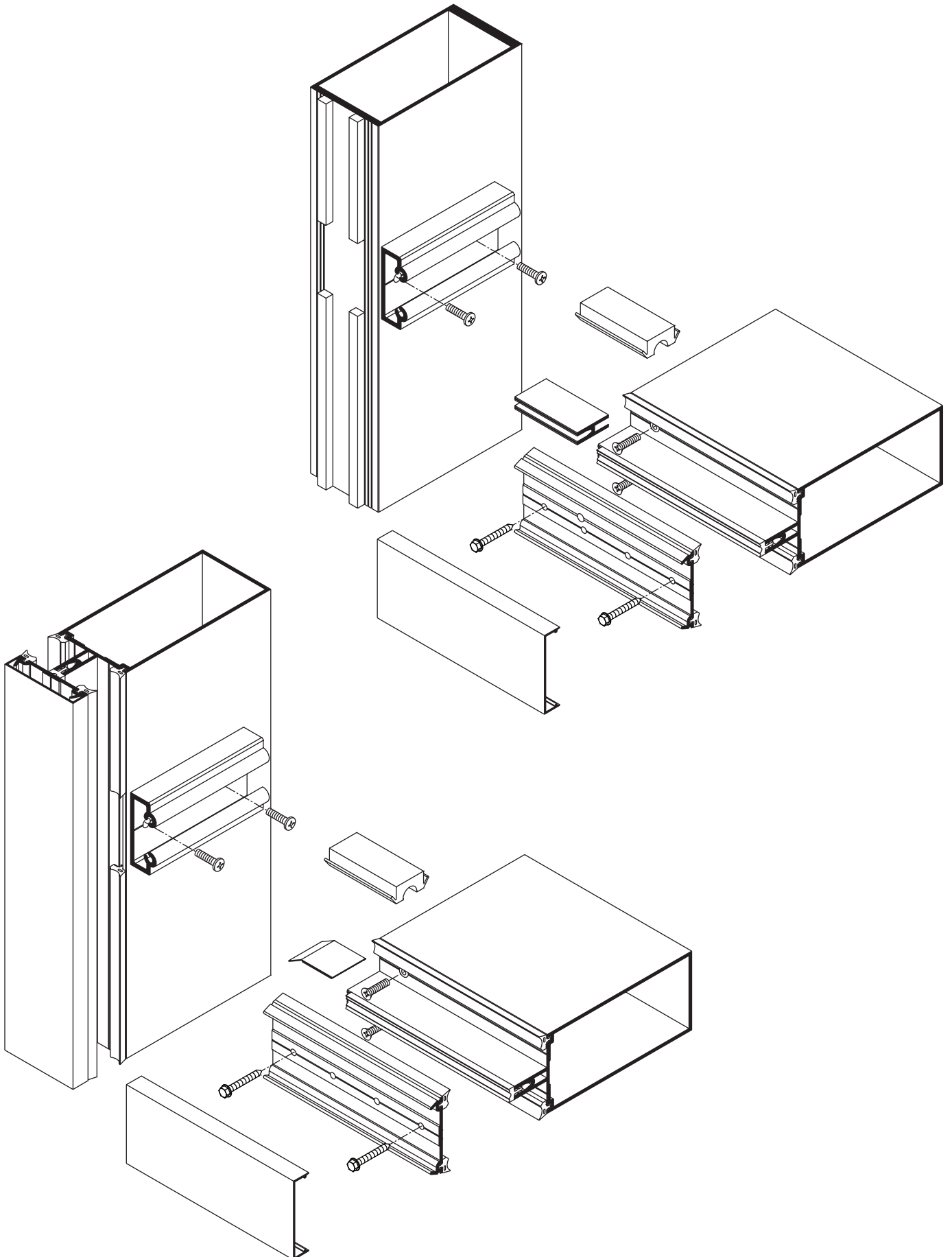

Additional information and CAD details are available at www.kawneer.com

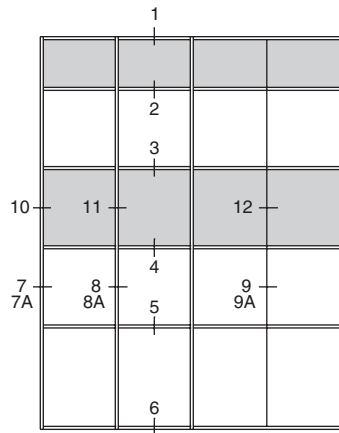

ELEVATION IS NUMBER KEYED TO DETAILS

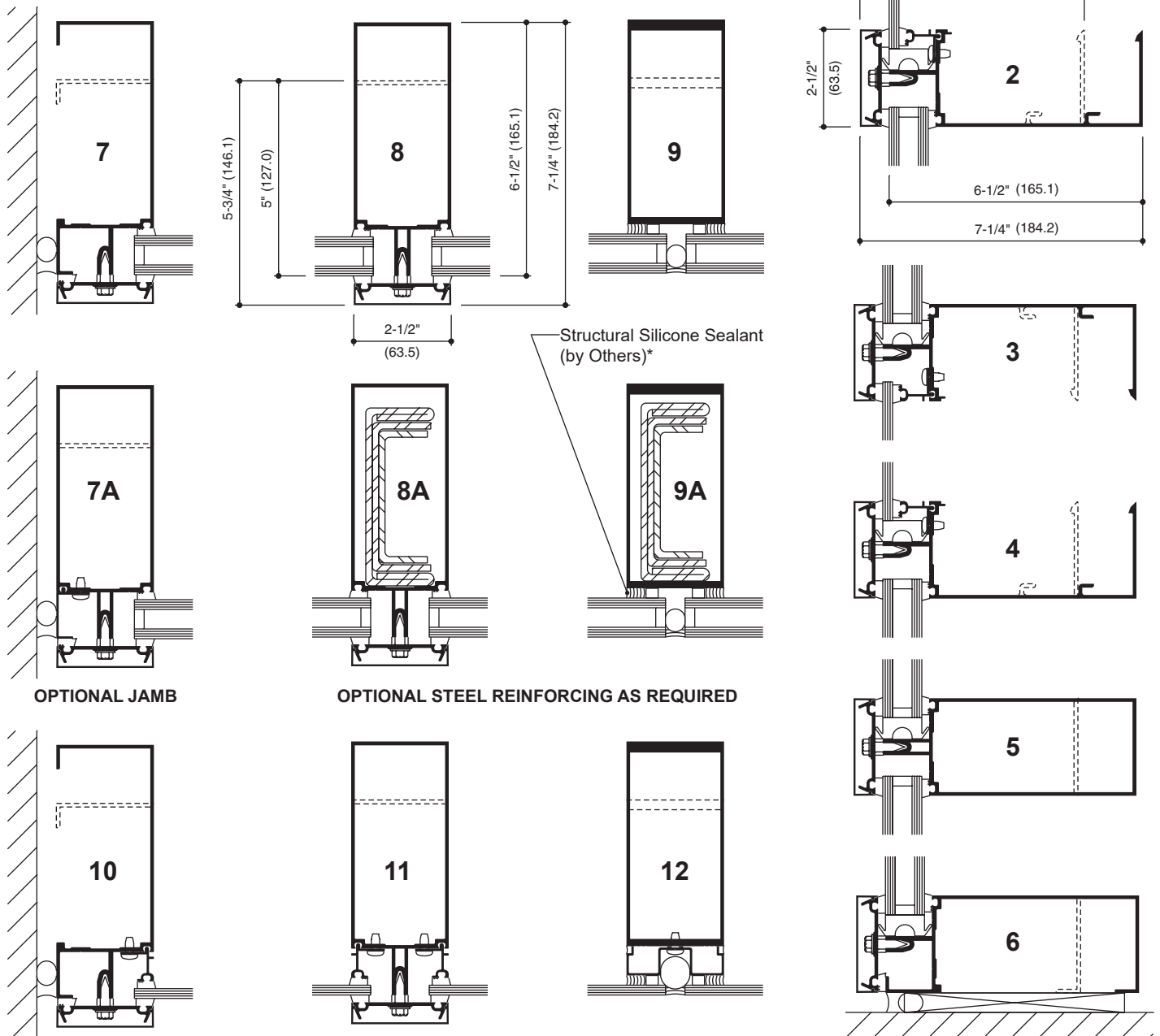

Structural Silicone Sealant (by Others)*

OPTIONAL JAMB

OPTIONAL STEEL REINFORCING AS REQUIRED

* INSTALLER NOTE: Installer is responsible for all required compatibility review and approvals with the Structural Silicone Manufacturer and the Insulating Glass Unit Manufacturer.

Laws and building and safety codes governing the design and use of Kawneer products, such as glazed entrance, window, and curtain wall products, vary widely. Kawneer does not control the selection of product configurations, operating hardware, or glazing materials, and assumes no responsibility therefor.

Kawneer reserves the right to change configuration without prior notice when deemed necessary for product improvement.

© 2013, Kawneer Company, Inc.

Additional information and CAD details are available at www.kawneer.com

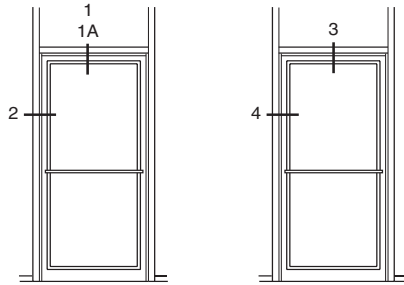

B/H OR O/P **C/H**
 ELEVATION IS NUMBER KEYED TO DETAILS

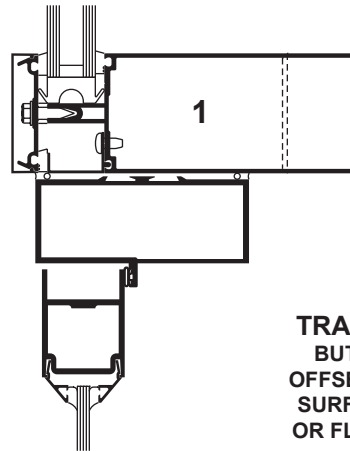

TRANSOM BAR
 BUTT HUNG OR
 OFFSET PIVOT WITH
 SURFACE CLOSER
 OR FLOOR CLOSER

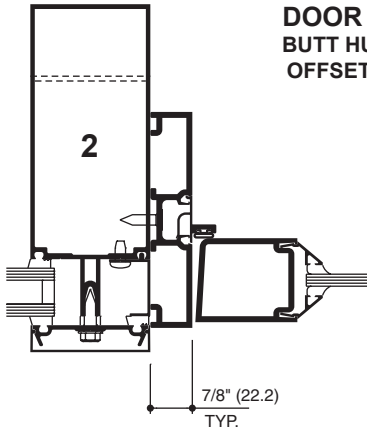

DOOR JAMB
 BUTT HUNG OR
 OFFSET PIVOT

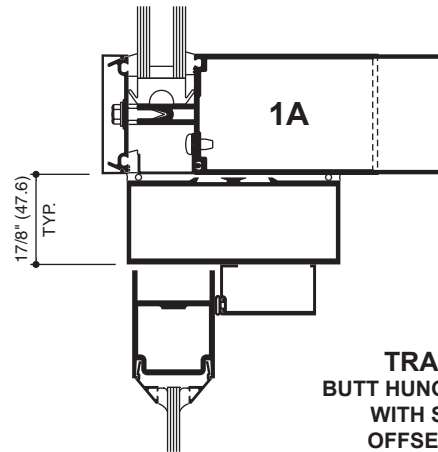

TRANSOM BAR
 BUTT HUNG OR OFFSET PIVOT
 WITH SINGLE ACTING
 OFFSET ARM CLOSER

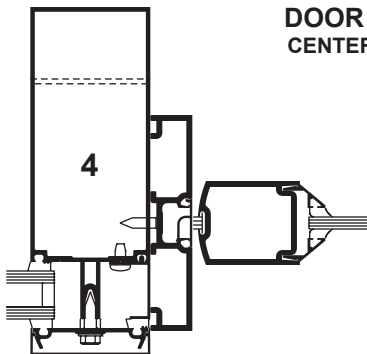

DOOR JAMB
 CENTER HUNG

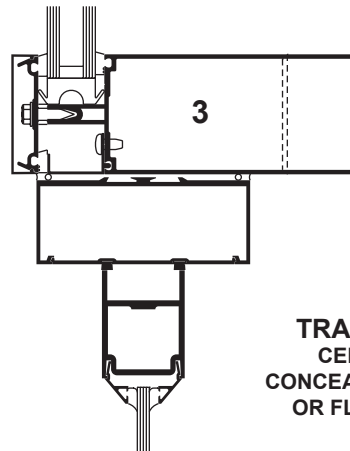

TRANSOM BAR
 CENTER HUNG
 CONCEALED OVERHEAD
 OR FLOOR CLOSER

Laws and building and safety codes governing the design and use of Kawneer products, such as glazed entrance, window, and curtain wall products, vary widely. Kawneer does not control the selection of product configurations, operating hardware, or glazing materials, and assumes no responsibility therefor.

Kawneer reserves the right to change configuration without prior notice when deemed necessary for product improvement.
 © 2013, Kawneer Company, Inc.

Additional information and CAD details are available at www.kawneer.com

NOTE: 1" INFILL SHOWN, 1/4" INFILL SIMILAR.
7-1/4" SYSTEM SHOWN, 5-3/4" SYSTEM SIMILAR.

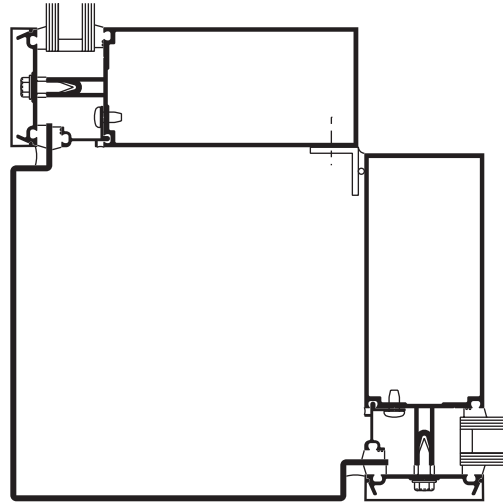

90° OUTSIDE CORNER

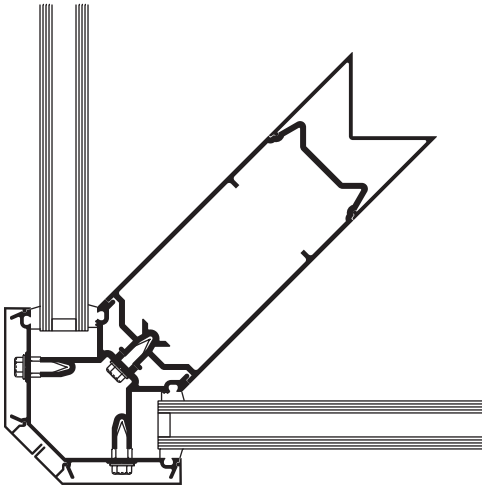

90° OUTSIDE CORNER

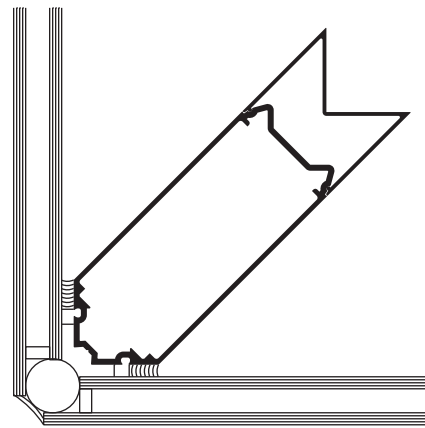

90° SSG OUTSIDE CORNER

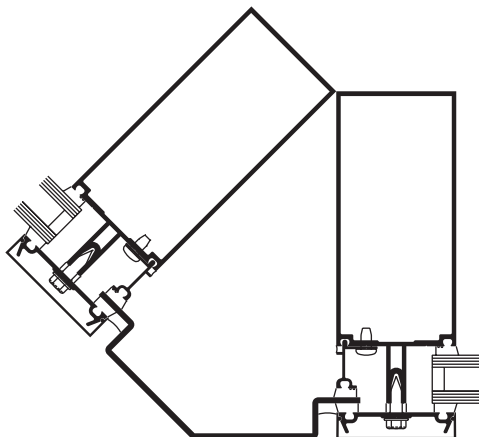

135° OUTSIDE CORNER

Structural Silicone Sealant
(by Others)*

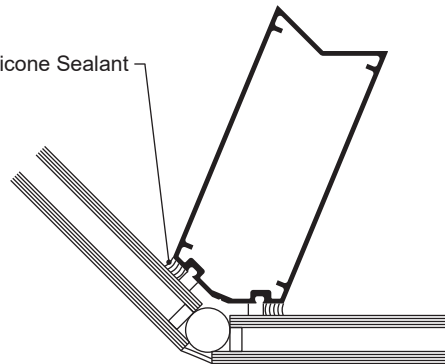

135° SSG OUTSIDE CORNER

* **INSTALLER NOTE:** Installer is responsible for all required compatibility review and approvals with the Structural Silicone Manufacturer and the Insulating Glass Unit Manufacturer.

Laws and building and safety codes governing the design and use of Kawneer products, such as glazed entrance, window, and curtain wall products, vary widely. Kawneer does not control the selection of product configurations, operating hardware, or glazing materials, and assumes no responsibility therefor.

Kawneer reserves the right to change configuration without prior notice when deemed necessary for product improvement.
© 2013, Kawneer Company, Inc.

Additional information and CAD details are available at www.kawneer.com

NOTE: 1" INFILL SHOWN, 1/4" INFILL SIMILAR.
7-1/4" SYSTEM SHOWN, 5-3/4" SYSTEM SIMILAR.

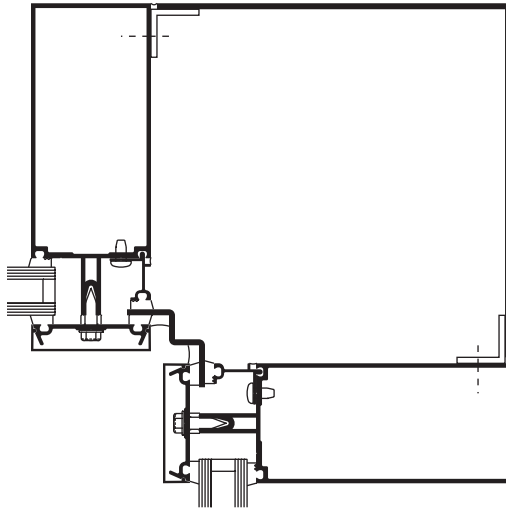

90° INSIDE CORNER

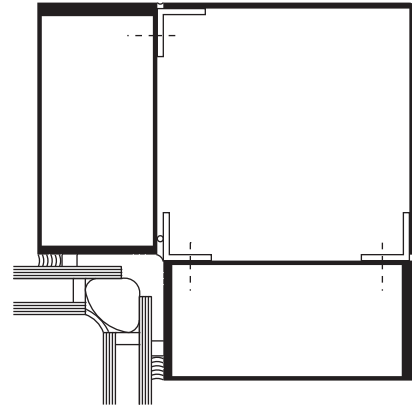

90° SSG INSIDE CORNER

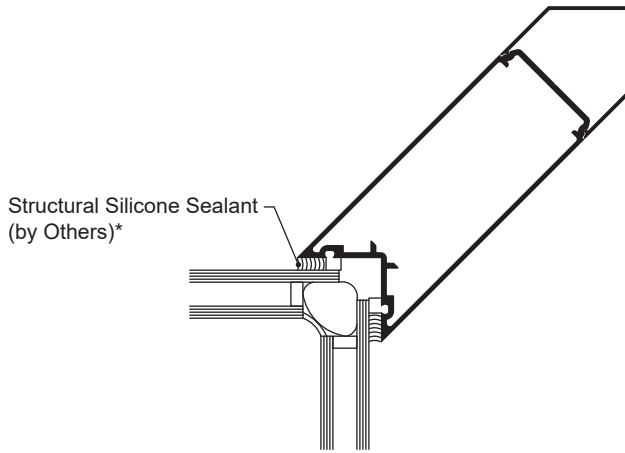

90° SSG INSIDE CORNER

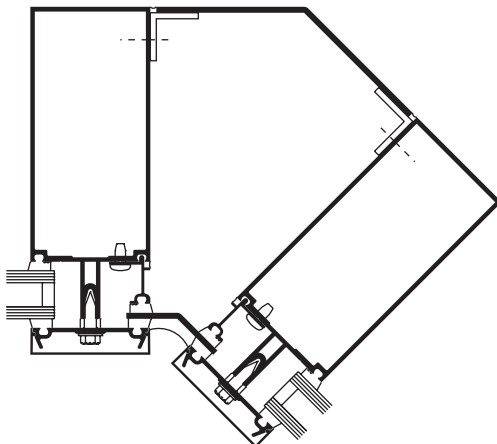

135° INSIDE CORNER

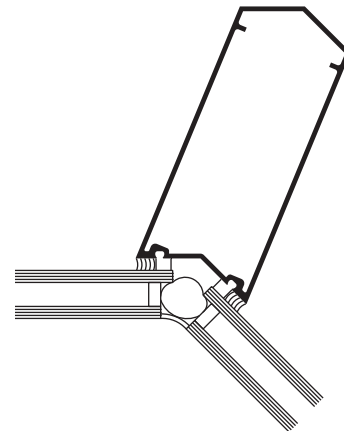

135° SSG INSIDE CORNER

*** INSTALLER NOTE:** Installer is responsible for all required compatibility review and approvals with the Structural Silicone Manufacturer and the Insulating Glass Unit Manufacturer.

Laws and building and safety codes governing the design and use of Kawneer products, such as glazed entrance, window, and curtain wall products, vary widely. Kawneer does not control the selection of product configurations, operating hardware, or glazing materials, and assumes no responsibility therefor.

Kawneer reserves the right to change configuration without prior notice when deemed necessary for product improvement.
© 2013, Kawneer Company, Inc.

Additional information and CAD details are available at www.kawneer.com

SEF GLASSvent® WINDOWS FOR STOREFRONT FRAMING

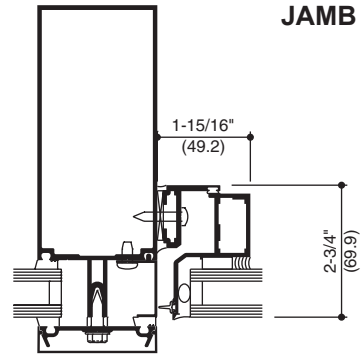
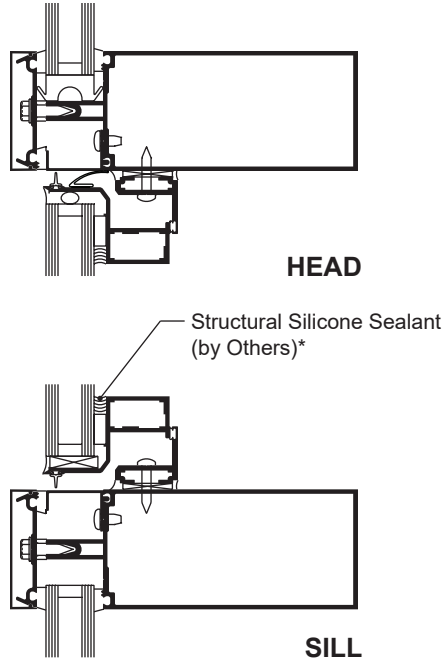

GLASSvent® WINDOWS FOR CURTAIN WALL

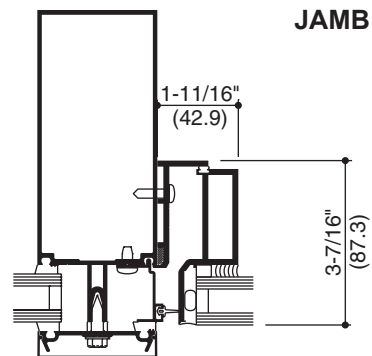
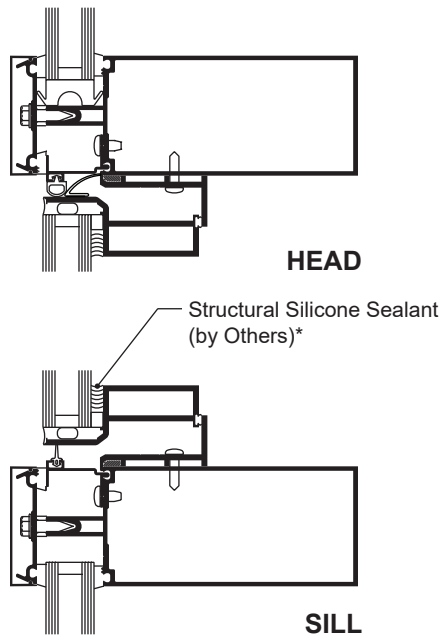

* INSTALLER NOTE: Installer is responsible for all required compatibility review and approvals with the Structural Silicone Manufacturer and the Insulating Glass Unit Manufacturer.

Additional information and CAD details are available at www.kawneer.com

8225TL THERMAL WINDOWS

NOTE: Other vent types can be accommodated. Contact your Kawneer representative for other options.

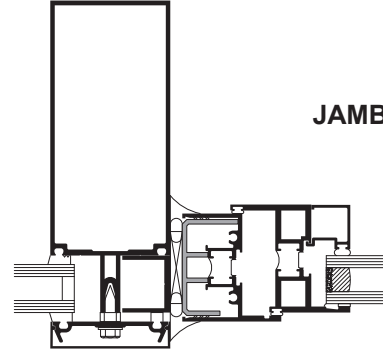
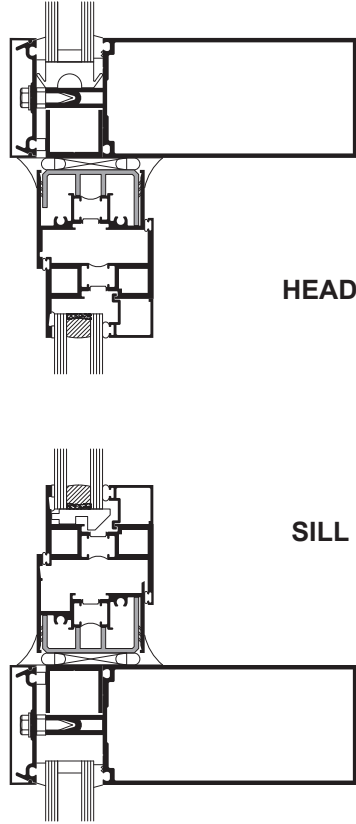

Laws and building and safety codes governing the design and use of Kawneer products, such as glazed entrance, window, and curtain wall products, vary widely. Kawneer does not control the selection of product configurations, operating hardware, or glazing materials, and assumes no responsibility therefor.

Kawneer reserves the right to change configuration without prior notice when deemed necessary for product improvement.
© 2013, Kawneer Company, Inc.

Additional information and CAD details are available at www.kawneer.com

Actual project conditions will determine specific anchor design.

Details on this page are reference only. Captured mullions shown, SSG mullion similar.

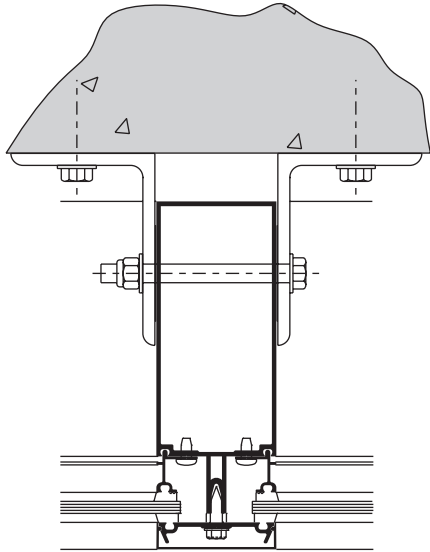

ANCHOR TO FLOOR SLAB

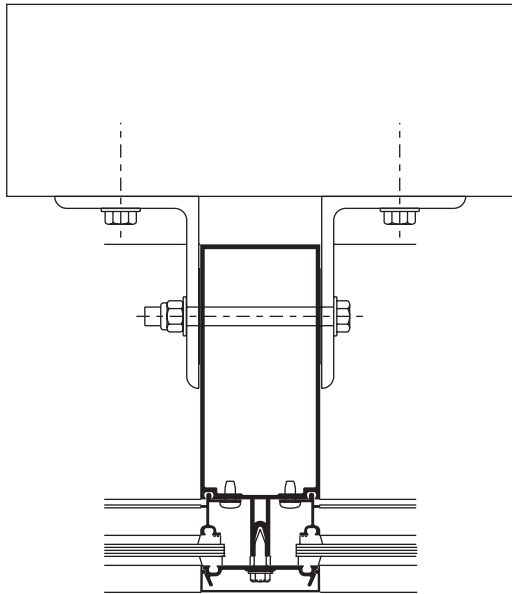
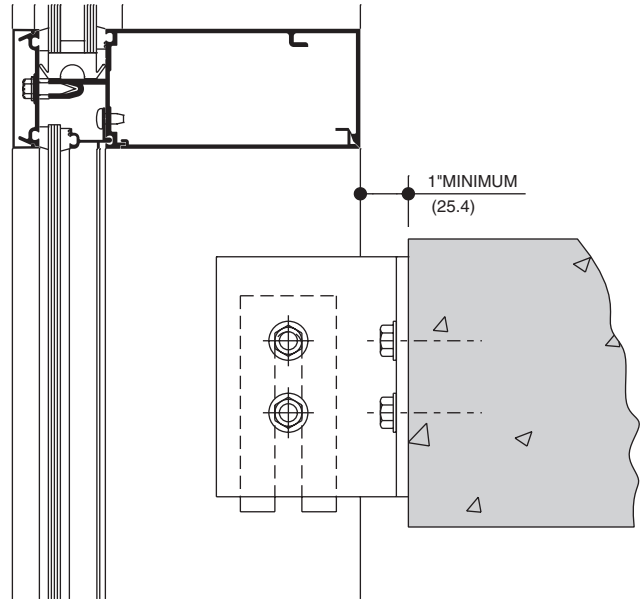

ANCHOR TO SUPPORT STEEL

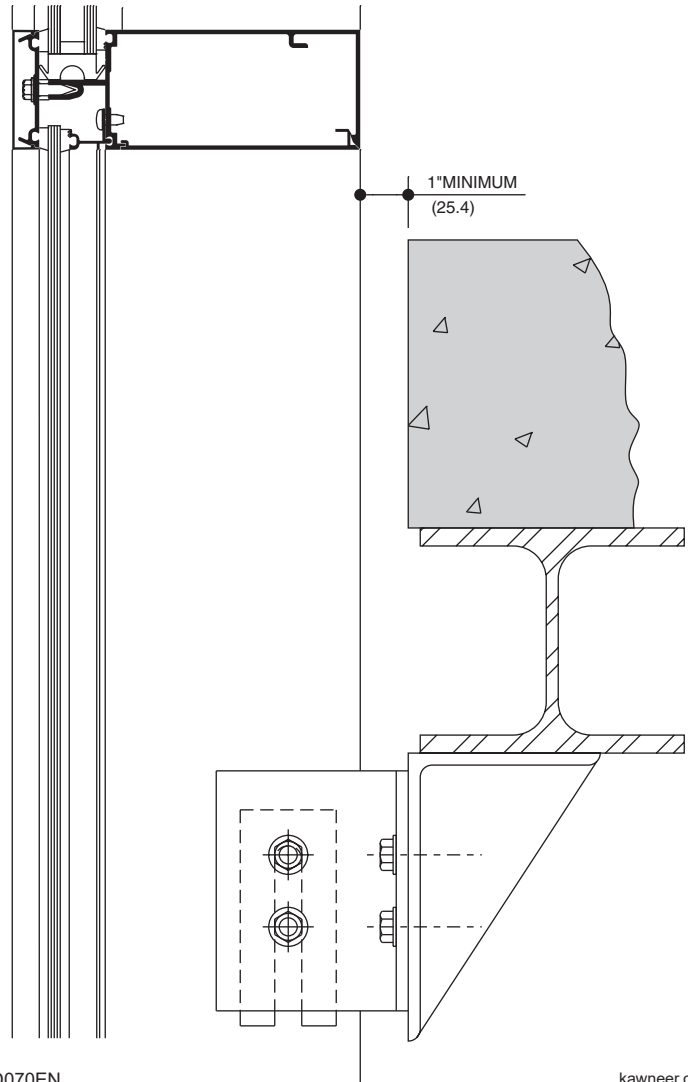

Laws and building and safety codes governing the design and use of Kawneer products, such as glazed entrance, window, and curtain wall products, vary widely. Kawneer does not control the selection of product configurations, operating hardware, or glazing materials, and assumes no responsibility therefor.

Kawneer reserves the right to change configuration without prior notice when deemed necessary for product improvement.
© 2013, Kawneer Company, Inc.

Additional information and CAD details are available at www.kawneer.com

Actual project conditions will determine specific anchor design.
Details on this page are reference only. Captured mullions shown, SSG mullion similar.

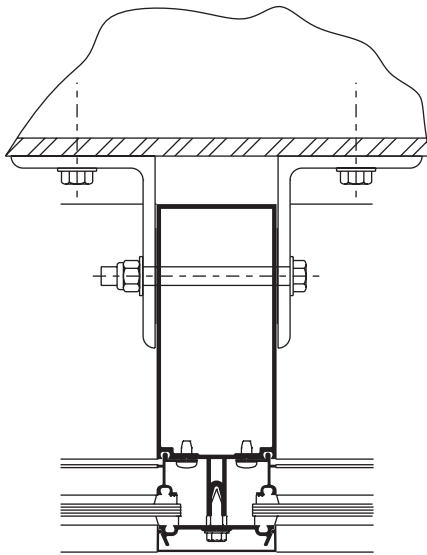

**ANCHOR TO HORIZONTAL
STEEL STRUCTURE**

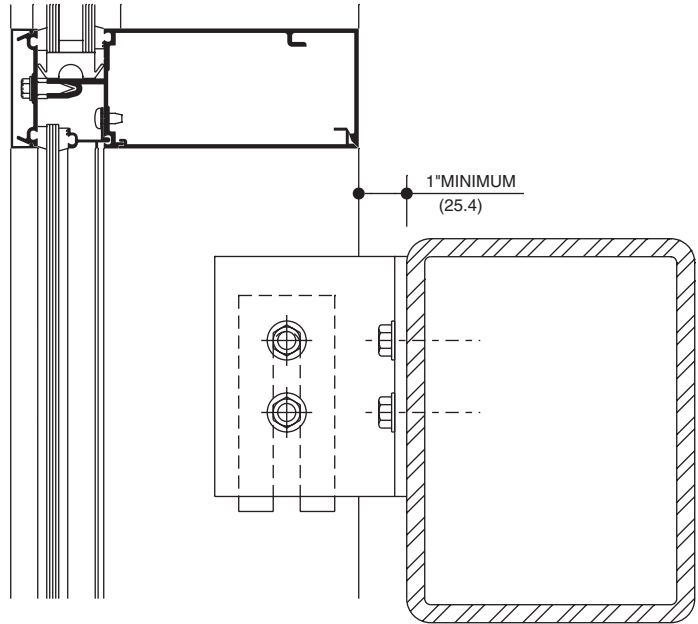

Laws and building and safety codes governing the design and use of Kawneer products, such as glazed entrance, window, and curtain wall products, vary widely. Kawneer does not control the selection of product configurations, operating hardware, or glazing materials, and assumes no responsibility therefor.

Kawneer reserves the right to change configuration without prior notice when deemed necessary for product improvement.
© 2013, Kawneer Company, Inc.

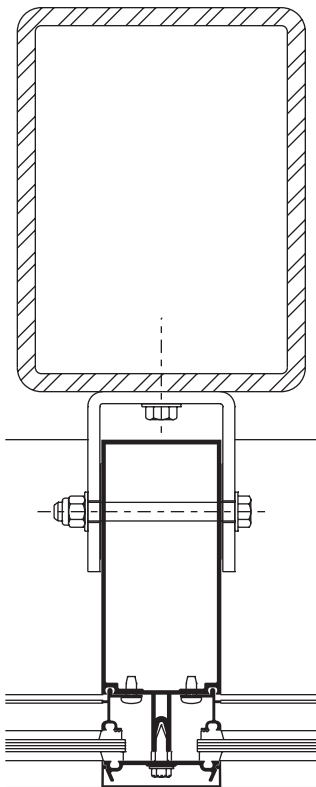

**ANCHOR TO VERTICAL
STEEL STRUCTURE**

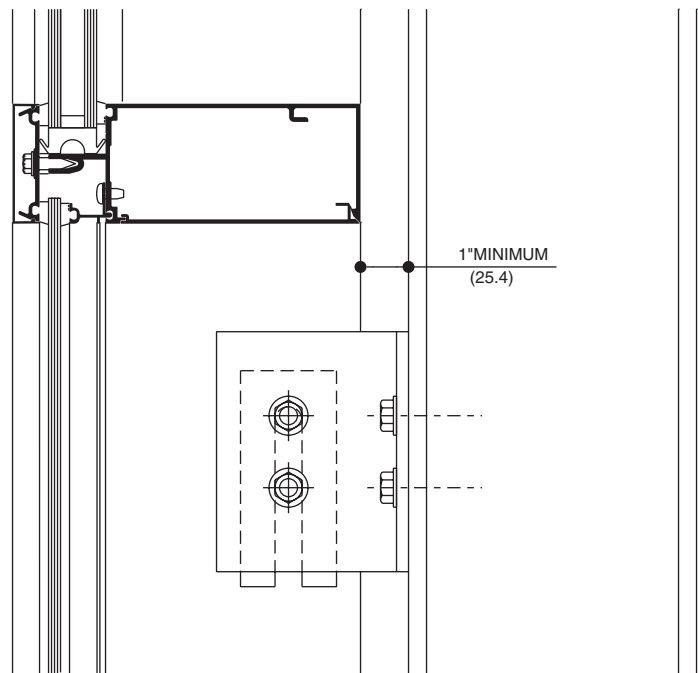

WIND LOAD CHARTS

Mullions are designed for deflection limitations in accordance with AAMA TIR-A11 of L/175 up to 13' 6" and L/240 +1/4" above 13' 6". These curves are for mullions WITH HORIZONTALS and are based on engineering calculations for stress and deflection. Allowable wind load stress for ALUMINUM 15,152 psi (104 MPa), STEEL 30,000 psi (207 MPa). Charted curves, in all cases are for the limiting value. Wind load charts contained herein are based upon nominal wind load utilized in allowable stress design. A conversion from Load Resistance Factor Design (LRFD) is provided. To convert ultimate wind loads to nominal loads, multiply ultimate wind loads by a factor of 0.6 per ASCE/SEI 7. A 4/3 increase in allowable stress has not been used to develop these curves. For special situations not covered by these curves, contact your Kawneer representative for additional information.

DEADLOAD CHARTS

Horizontal or deadload limitations are based upon 1/8" (3.2), maximum allowable deflection at the center of an intermediate horizontal member. The accompanying charts are calculated for 1" (25.4) thick insulating glass or 1-3/4" (44.5) thick glass supported on two setting blocks placed at the loading points shown.

Laws and building and safety codes governing the design and use of Kawneer products, such as glazed entrance, window, and curtain wall products, vary widely. Kawneer does not control the selection of product configurations, operating hardware, or glazing materials, and assumes no responsibility therefor.

Kawneer reserves the right to change configuration without prior notice when deemed necessary for product improvement.
© 2013, Kawneer Company, Inc.

	Allowable Stress Design Load	LRFD Ultimate Design Load
A =	20 PSF (960)	33 PSF (1580)
B =	30 PSF (1440)	50 PSF (2400)
C =	40 PSF (1920)	67 PSF (3200)
D =	50 PSF (2400)	83 PSF (4000)
E =	60 PSF (2880)	100 PSF (4790)

SINGLE SPAN

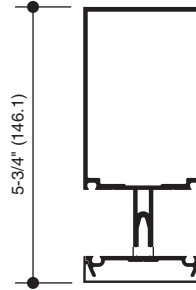
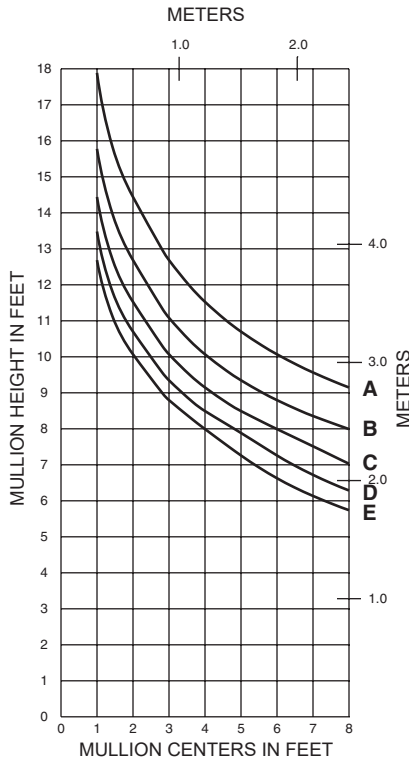

168001

$I = 4.025 (167.53 \times 10^4)$
 $S = 1.565 (25.65 \times 10^3)$

TWIN SPAN

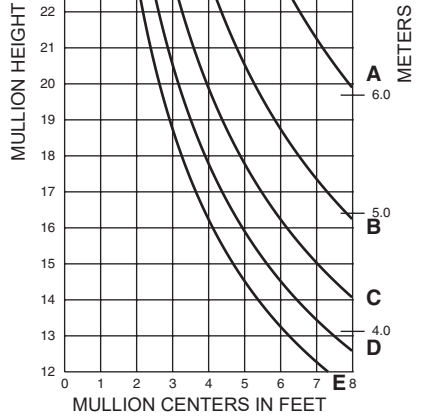
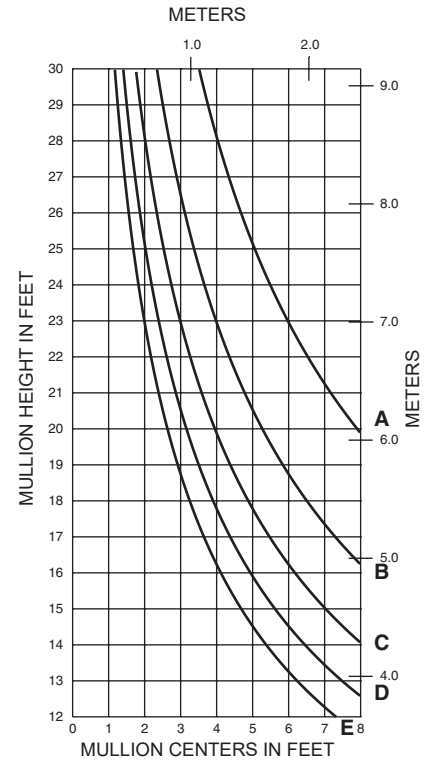

168011

$I = 8.250 (343.39 \times 10^4)$
 $S = 2.528 (41.43 \times 10^3)$

SINGLE SPAN

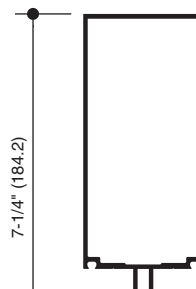
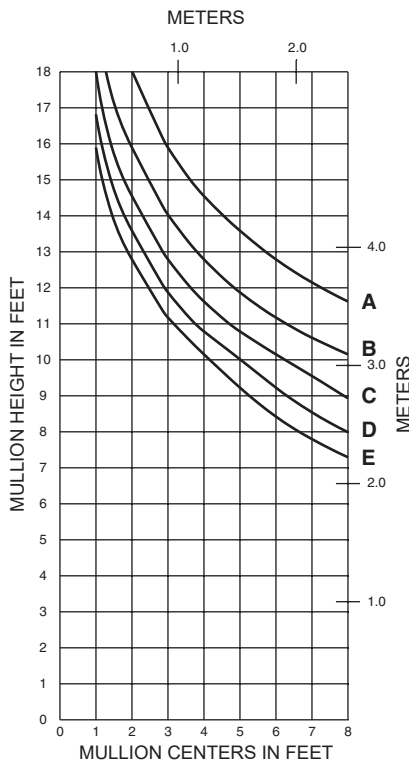

168011

$I = 8.250 (343.39 \times 10^4)$
 $S = 2.528 (41.43 \times 10^3)$

TWIN SPAN

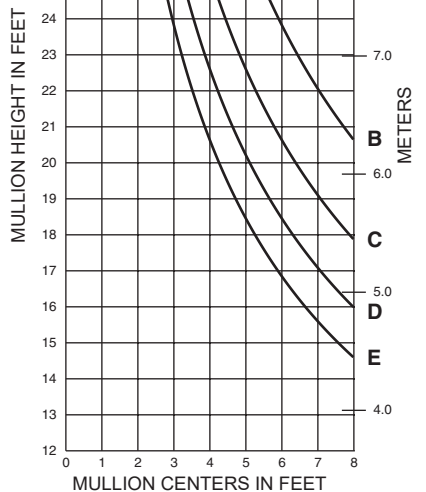
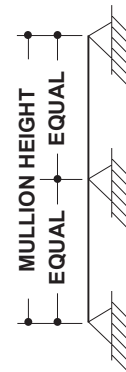
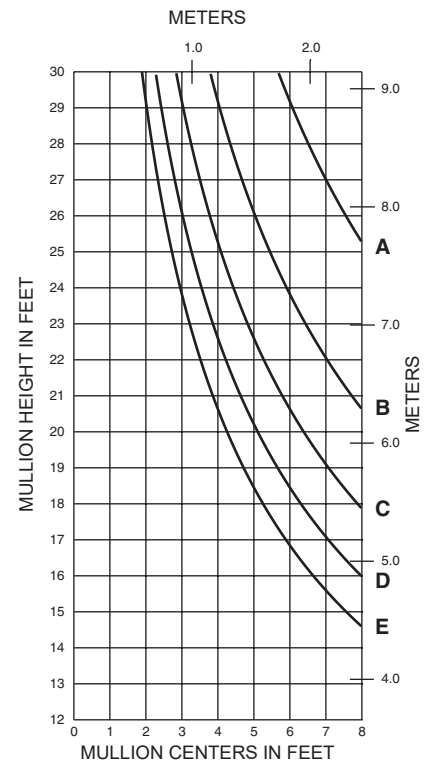

Laws and building and safety codes governing the design and use of Kawneer products, such as glazed entrance, window, and curtain wall products, vary widely. Kawneer does not control the selection of product configurations, operating hardware, or glazing materials, and assumes no responsibility therefor.

Kawneer reserves the right to change configuration without prior notice when deemed necessary for product improvement.
 © 2013, Kawneer Company, Inc.

	Allowable Stress Design Load	LRFD Ultimate Design Load
A =	20 PSF (960)	33 PSF (1580)
B =	30 PSF (1440)	50 PSF (2400)
C =	40 PSF (1920)	67 PSF (3200)
D =	50 PSF (2400)	83 PSF (4000)
E =	60 PSF (2880)	100 PSF (4790)

SINGLE SPAN

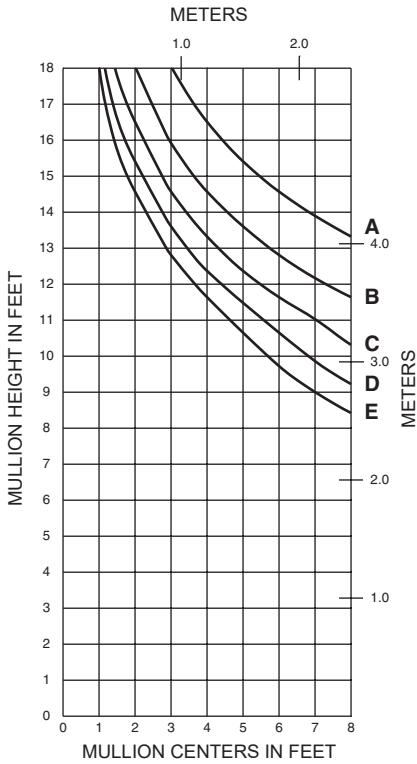

TWIN SPAN

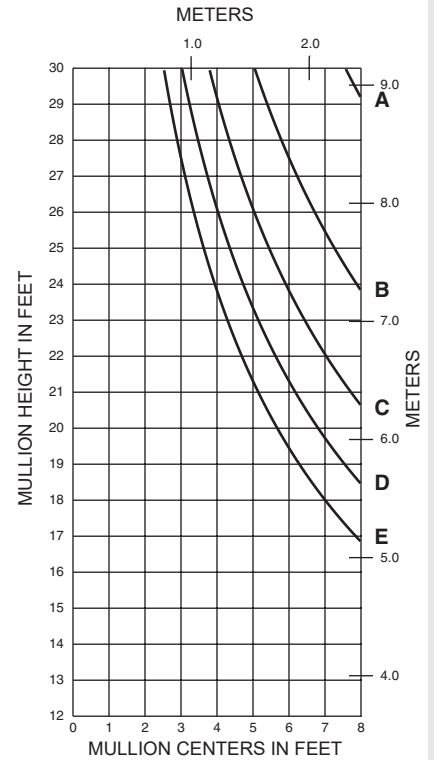

SINGLE SPAN 168015 w/ 162300

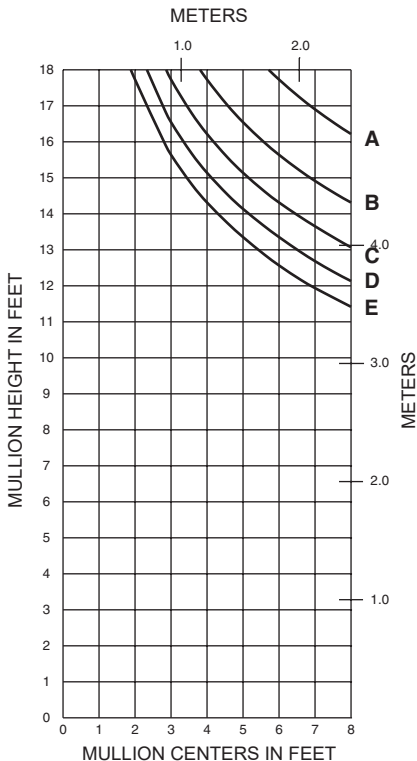

TWIN SPAN 168015 w/ 162300

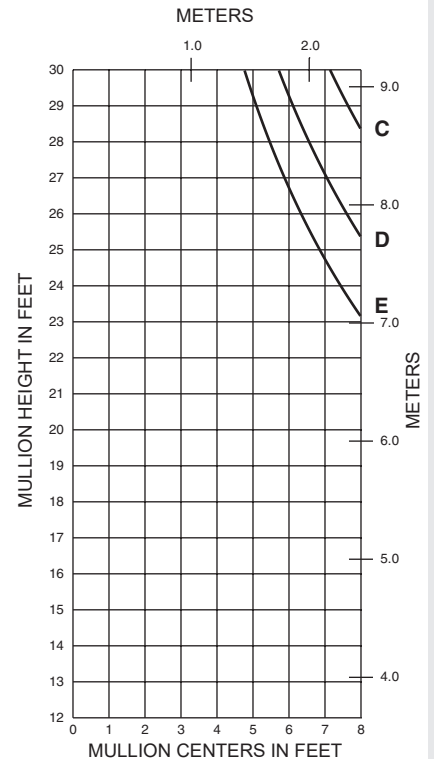

168015
 $I = 12.438 (517.71 \times 10^4)$
 $S = 3.371 (55.24 \times 10^3)$

168015 w/ 162300
 $I_a = 12.438 (517.71 \times 10^4)$
 $S_a = 3.371 (55.24 \times 10^3)$
 $I_s = 3.805 (158.38 \times 10^4)$
 $S_s = 1.669 (27.35 \times 10^3)$

Laws and building and safety codes governing the design and use of Kawneer products, such as glazed entrance, window, and curtain wall products, vary widely. Kawneer does not control the selection of product configurations, operating hardware, or glazing materials, and assumes no responsibility therefor.

Kawneer reserves the right to change configuration without prior notice when deemed necessary for product improvement.
 © 2013, Kawneer Company, Inc.

SINGLE SPAN 168015 w/ 162301

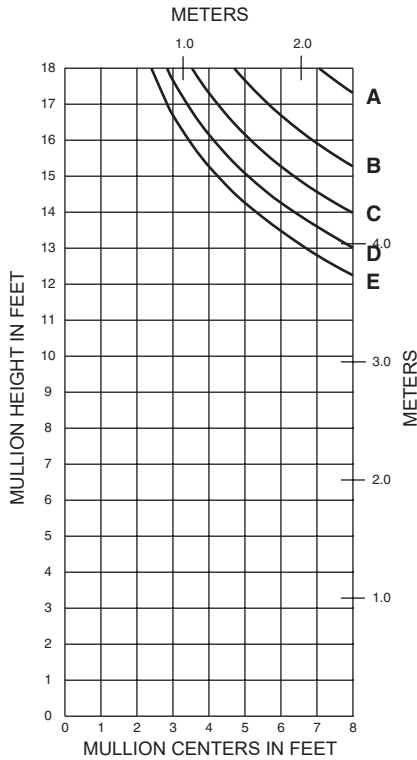

	Allowable Stress Design Load	LRFD Ultimate Design Load
A =	20 PSF (960)	33 PSF (1580)
B =	30 PSF (1440)	50 PSF (2400)
C =	40 PSF (1920)	67 PSF (3200)
D =	50 PSF (2400)	83 PSF (4000)
E =	60 PSF (2880)	100 PSF (4790)

TWIN SPAN 168015 w/ 162301

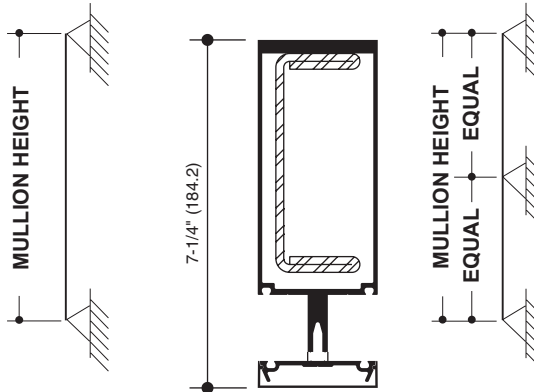
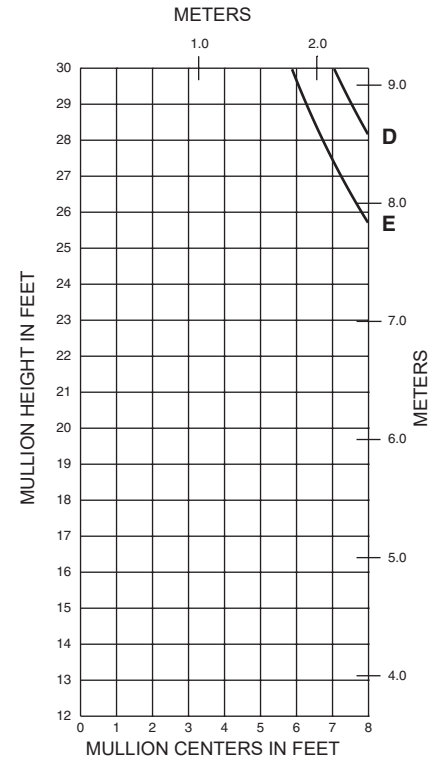

168015 w/ 162301

la = 12.438 (517.71 x 10⁴)
 Sa = 3.371 (55.24 x 10³)
 ls = 5.684 (236.59 x 10³)
 Ss = 2.493 (40.85 x 10³)

SINGLE SPAN 168015 w/ 162301/302

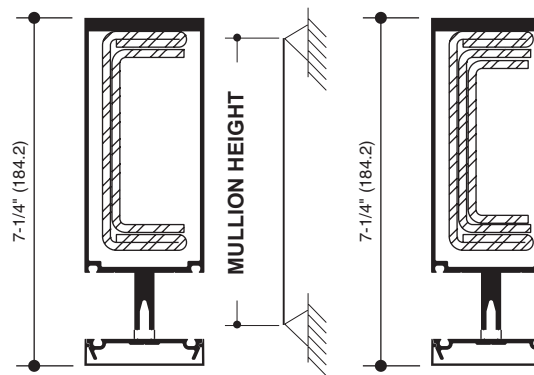
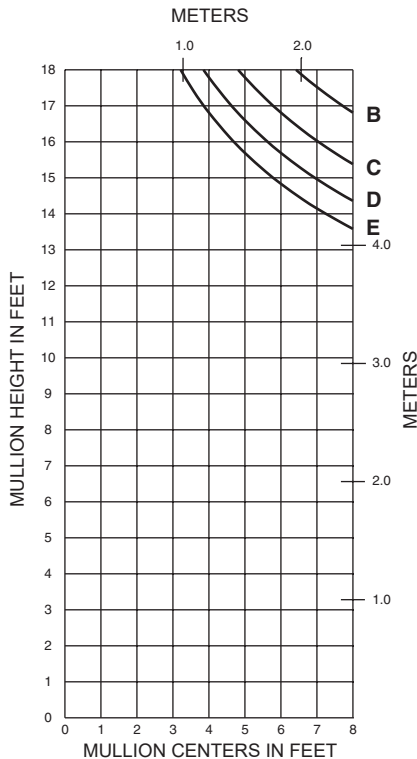

168015 w/ 162301/302

la = 12.438 (517.71 x 10⁴)
 Sa = 3.371 (55.24 x 10³)
 ls = 7.893 (328.53 x 10³)
 Ss = 3.462 (56.73 x 10³)

**168015
w/ 162301/302/303**

la = 12.438 (517.71 x 10⁴)
 Sa = 3.371 (55.24 x 10³)
 ls = 9.347 (389.05 x 10³)
 Ss = 4.100 (67.19 x 10³)

SINGLE SPAN 168015 w/ 162301/302/303

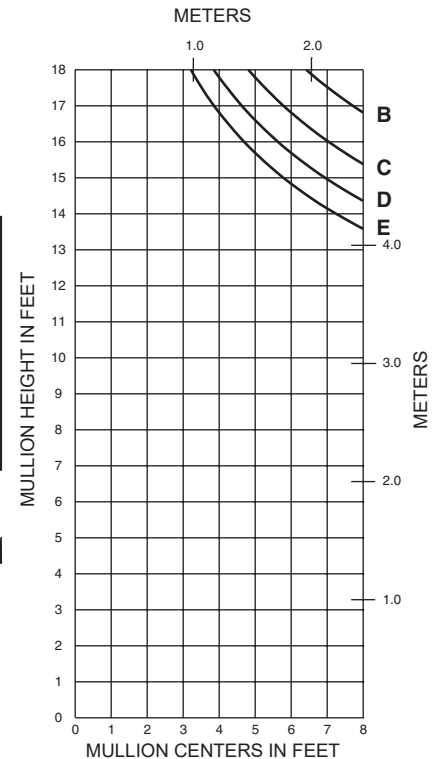

Laws and building and safety codes governing the design and use of Kawneer products, such as glazed entrance, window, and curtain wall products, vary widely. Kawneer does not control the selection of product configurations, operating hardware, or glazing materials, and assumes no responsibility therefor.

Kawneer reserves the right to change configuration without prior notice when deemed necessary for product improvement.
 © 2013, Kawneer Company, Inc.

	Allowable Stress Design Load	LRFD Ultimate Design Load
A =	20 PSF (960)	33 PSF (1580)
B =	30 PSF (1440)	50 PSF (2400)
C =	40 PSF (1920)	67 PSF (3200)
D =	50 PSF (2400)	83 PSF (4000)
E =	60 PSF (2880)	100 PSF (4790)

SINGLE SPAN

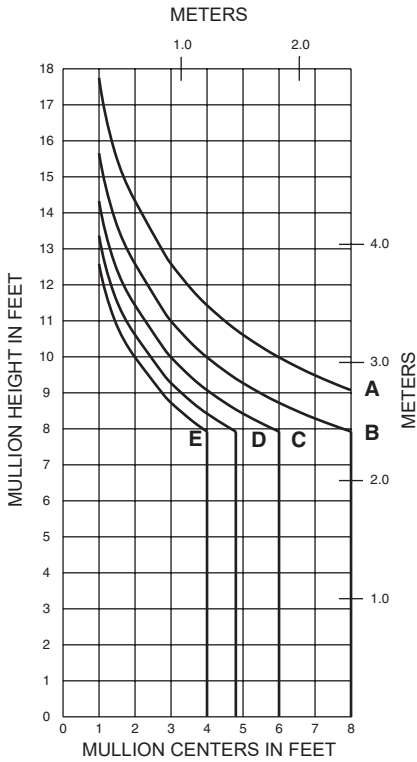

168004

I = 3.926 (163.41 x 10⁴)
S = 1.946 (31.89 x 10³)

TWIN SPAN

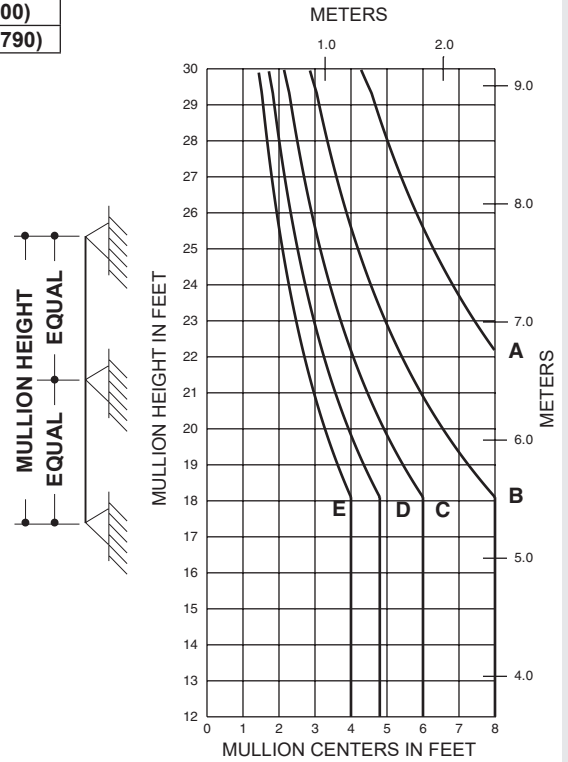

SINGLE SPAN

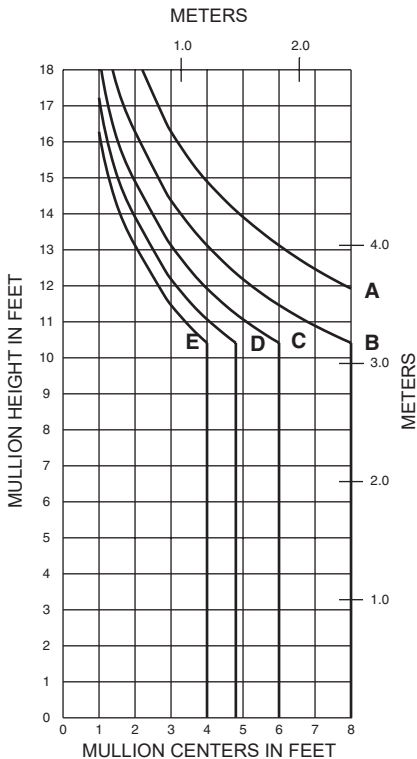

168014

I = 8.912 (370.95 x 10⁴)
S = 3.090 (50.64 x 10³)

TWIN SPAN

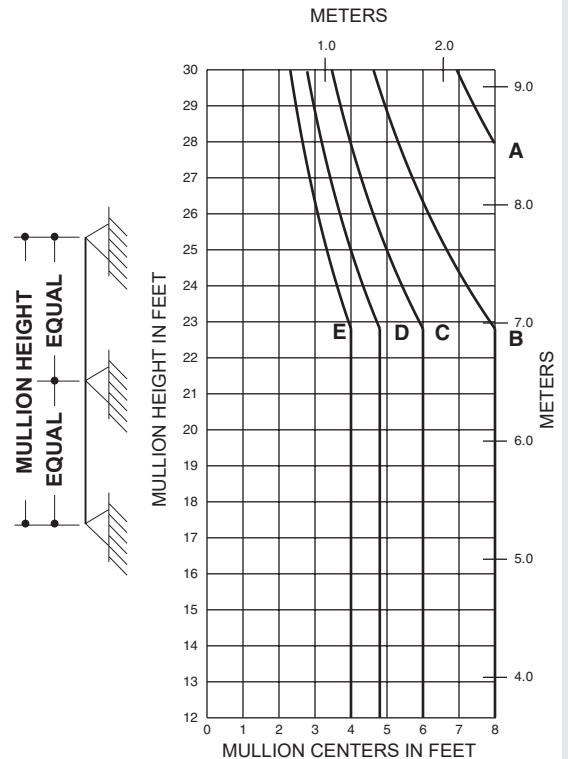

Laws and building and safety codes governing the design and use of Kawneer products, such as glazed entrance, window, and curtain wall products, vary widely. Kawneer does not control the selection of product configurations, operating hardware, or glazing materials, and assumes no responsibility therefor.

Kawneer reserves the right to change configuration without prior notice when deemed necessary for product improvement.
© 2013, Kawneer Company, Inc.

SINGLE SPAN 168014 w/ 162300

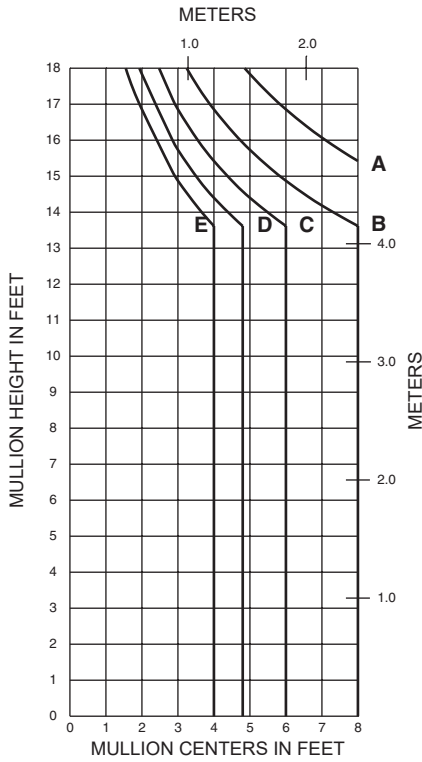

	Allowable Stress Design Load	LRFD Ultimate Design Load
A =	20 PSF (960)	33 PSF (1580)
B =	30 PSF (1440)	50 PSF (2400)
C =	40 PSF (1920)	67 PSF (3200)
D =	50 PSF (2400)	83 PSF (4000)
E =	60 PSF (2880)	100 PSF (4790)

TWIN SPAN 168014 w/ 162300

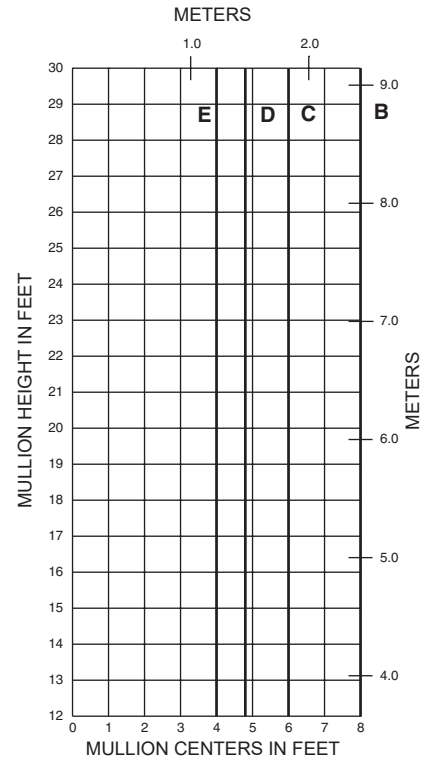

SINGLE SPAN 168014 w/ 162301

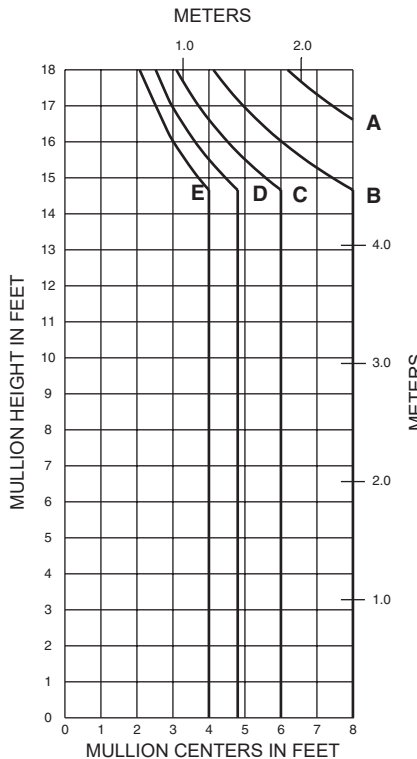

168014 w/ 162301

la = 8.912 (370.95 x 10⁴)
 Sa = 3.090 (50.64 x 10³)
 ls = 5.684 (236.59 x 10⁴)
 Ss = 2.493 (40.85 x 10³)

168014 w/ 162301/302

la = 8.912 (370.95 x 10⁴)
 Sa = 3.090 (50.64 x 10³)
 ls = 7.893 (328.53 x 10⁴)
 Ss = 3.462 (56.73 x 10³)

SINGLE SPAN 168014 w/ 162301/302

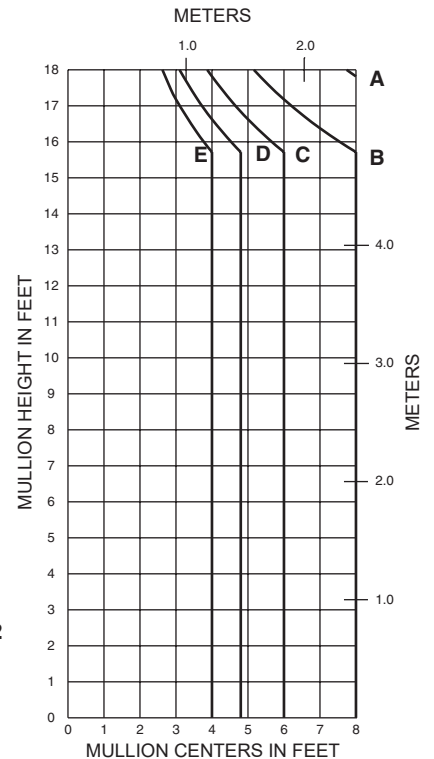

Laws and building and safety codes governing the design and use of Kawneer products, such as glazed entrance, window, and curtain wall products, vary widely. Kawneer does not control the selection of product configurations, operating hardware, or glazing materials, and assumes no responsibility therefor.

Kawneer reserves the right to change configuration without prior notice when deemed necessary for product improvement.
 © 2013, Kawneer Company, Inc.

SINGLE SPAN

168014 w/ 162301/302/303

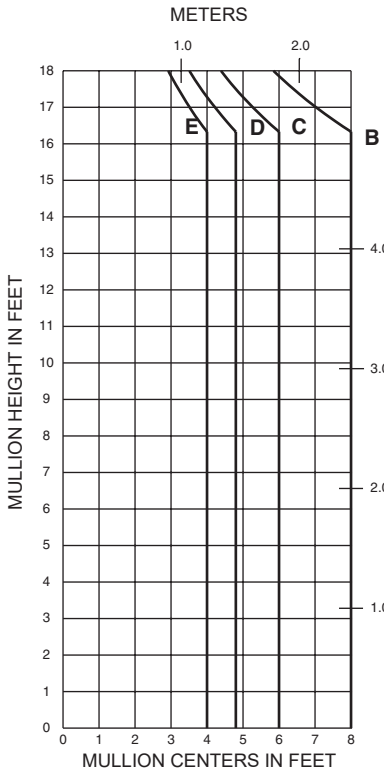

	Allowable Stress Design Load	LRFD Ultimate Design Load
A =	20 PSF (960)	33 PSF (1580)
B =	30 PSF (1440)	50 PSF (2400)
C =	40 PSF (1920)	67 PSF (3200)
D =	50 PSF (2400)	83 PSF (4000)
E =	60 PSF (2880)	100 PSF (4790)

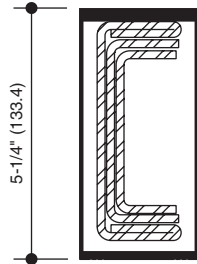

168014 w/ 162301/302/303

Ia = 8.912 (370.95 x 10⁴)
 Sa = 3.090 (50.64 x 10³)
 Is = 9.347 (389.05 x 10⁴)
 Ss = 4.100 (67.19 x 10³)

Laws and building and safety codes governing the design and use of Kawneer products, such as glazed entrance, window, and curtain wall products, vary widely. Kawneer does not control the selection of product configurations, operating hardware, or glazing materials, and assumes no responsibility therefor.

Kawneer reserves the right to change configuration without prior notice when deemed necessary for product improvement.
 © 2013, Kawneer Company, Inc.

A = 1/4 POINT LOADING
 B = 1/6 POINT LOADING
 C = 1/8 POINT LOADING

1" GLASS
168001

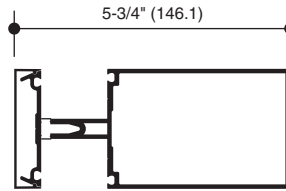
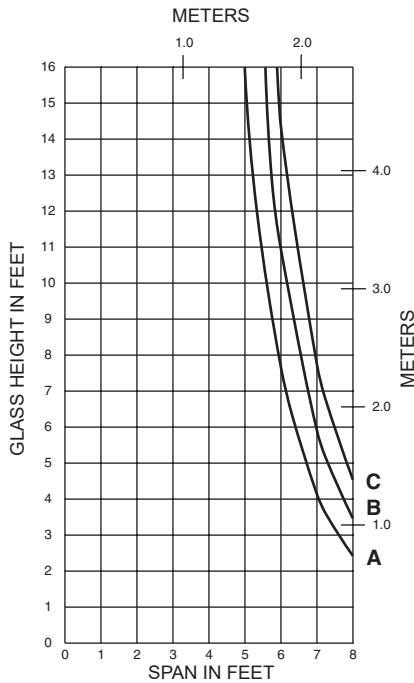

168001
 I = 1.278 (53.19 x 10⁴)
 S = 1.023 (16.76 x 10³)

1/4" GLASS
168001

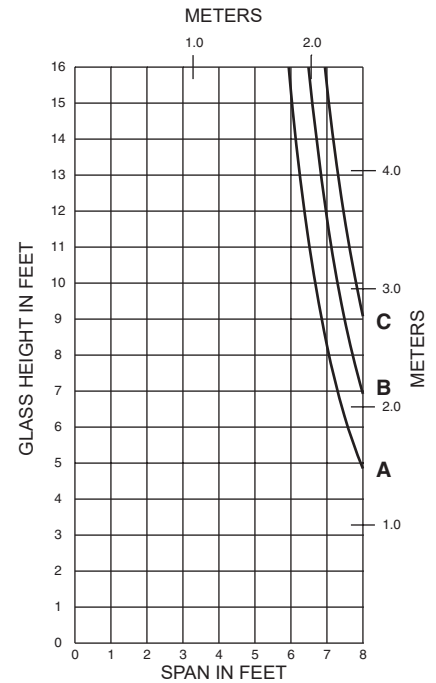

1/4" GLASS
168003

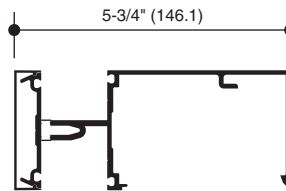
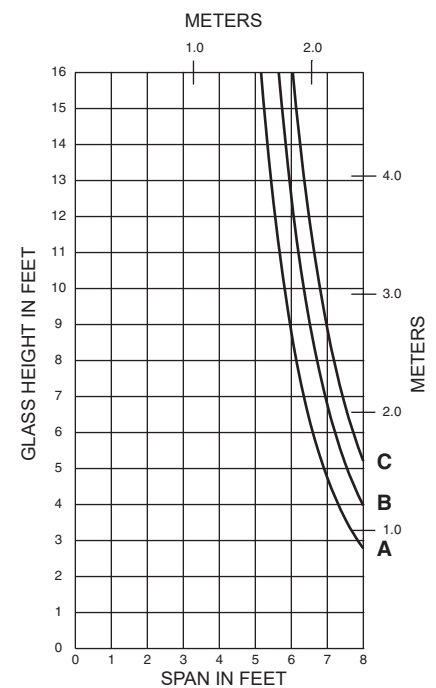

168003
 I = 0.733 (30.51 x 10⁴)
 S = 0.457 (7.49 x 10³)

1" GLASS
168003

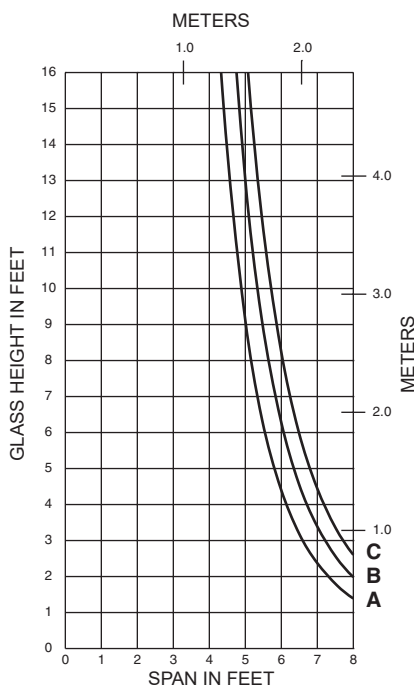

Laws and building and safety codes governing the design and use of Kawneer products, such as glazed entrance, window, and curtain wall products, vary widely. Kawneer does not control the selection of product configurations, operating hardware, or glazing materials, and assumes no responsibility therefor.

Kawneer reserves the right to change configuration without prior notice when deemed necessary for product improvement.
 © 2013, Kawneer Company, Inc.

A = 1/4 POINT LOADING
 B = 1/6 POINT LOADING
 C = 1/8 POINT LOADING

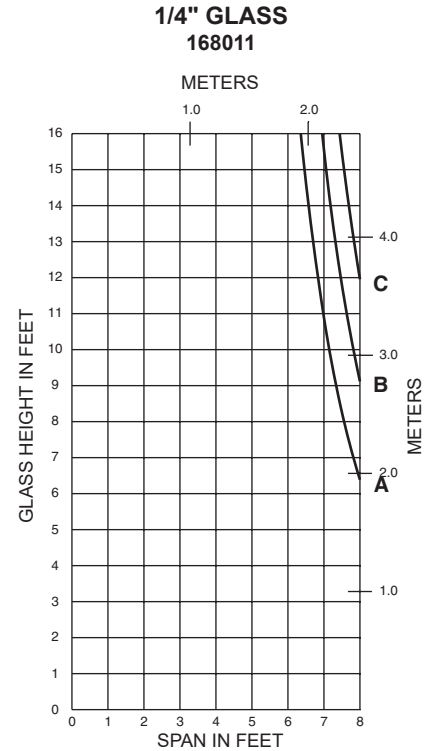
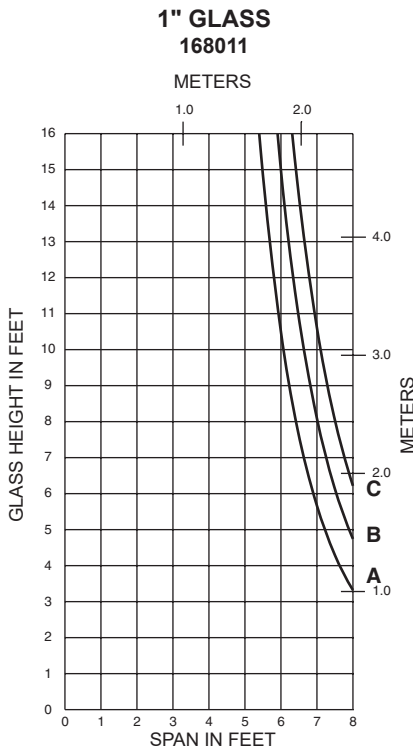
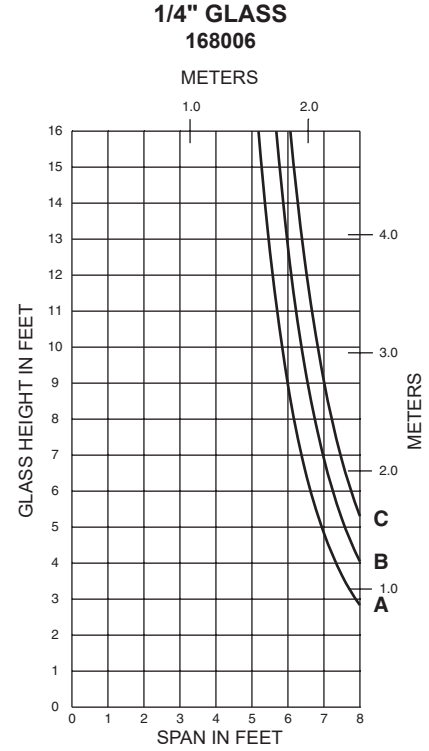
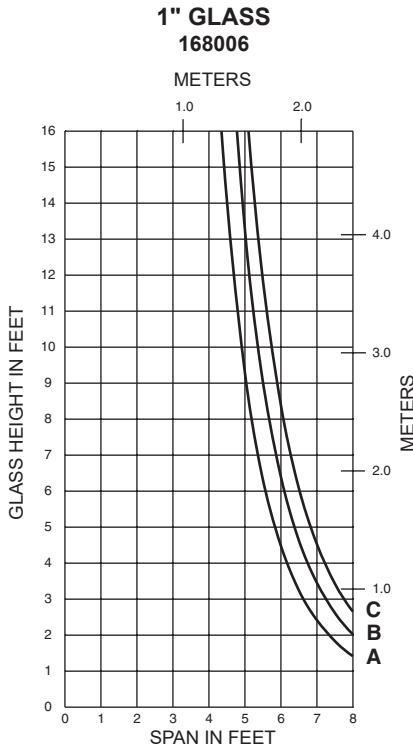

Laws and building and safety codes governing the design and use of Kawneer products, such as glazed entrance, window, and curtain wall products, vary widely. Kawneer does not control the selection of product configurations, operating hardware, or glazing materials, and assumes no responsibility therefor.

Kawneer reserves the right to change configuration without prior notice when deemed necessary for product improvement.
 © 2013, Kawneer Company, Inc.

A = 1/4 POINT LOADING
 B = 1/6 POINT LOADING
 C = 1/8 POINT LOADING

1" GLASS
168013

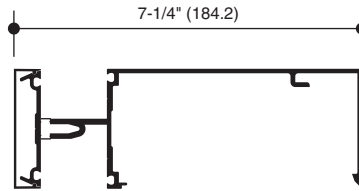
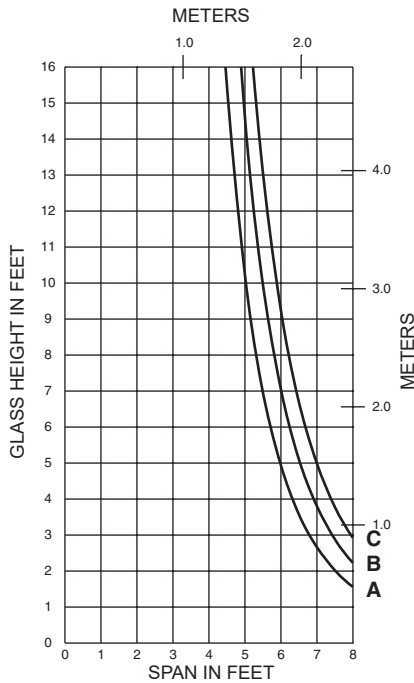

168013
 $I = 0.823 (34.26 \times 10^4)$
 $S = 0.487 (7.98 \times 10^3)$

1/4" GLASS
168013

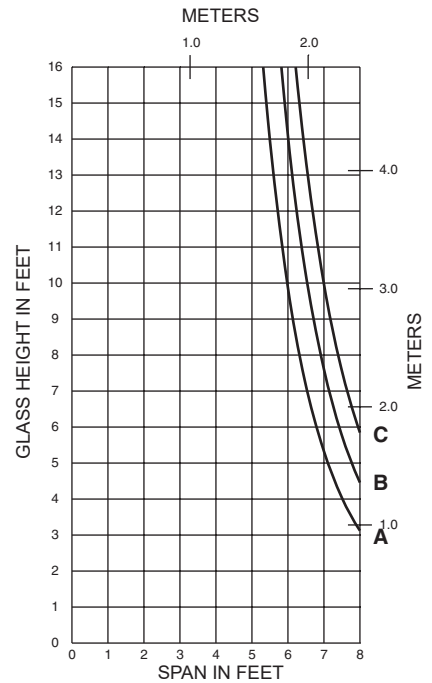

1/4" GLASS
168016

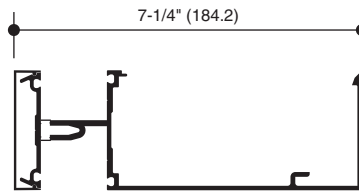
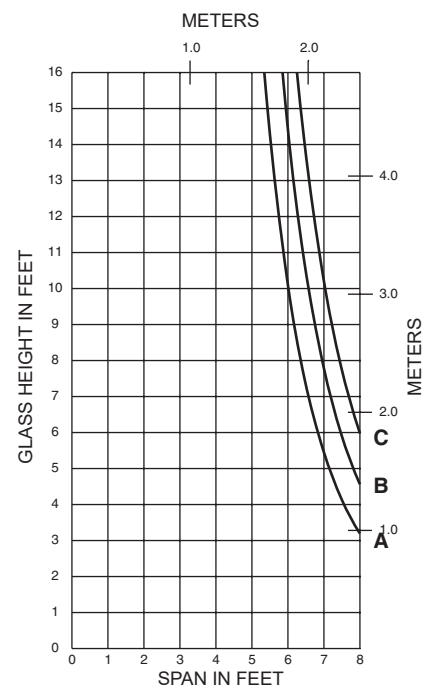

168016
 $I = 0.842 (35.05 \times 10^4)$
 $S = 0.503 (8.24 \times 10^3)$

1" GLASS
168016

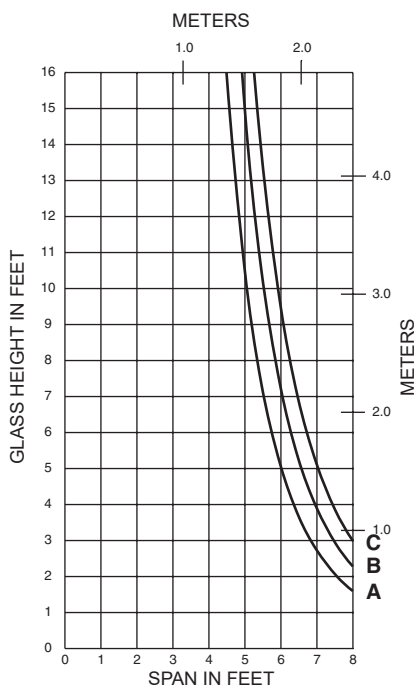

Laws and building and safety codes governing the design and use of Kawneer products, such as glazed entrance, window, and curtain wall products, vary widely. Kawneer does not control the selection of product configurations, operating hardware, or glazing materials, and assumes no responsibility therefor.

Kawneer reserves the right to change configuration without prior notice when deemed necessary for product improvement.
 © 2013, Kawneer Company, Inc.

**Project Specific U-factor
Example Calculation**
(Based on single bay of Curtain Wall/Window Wall)

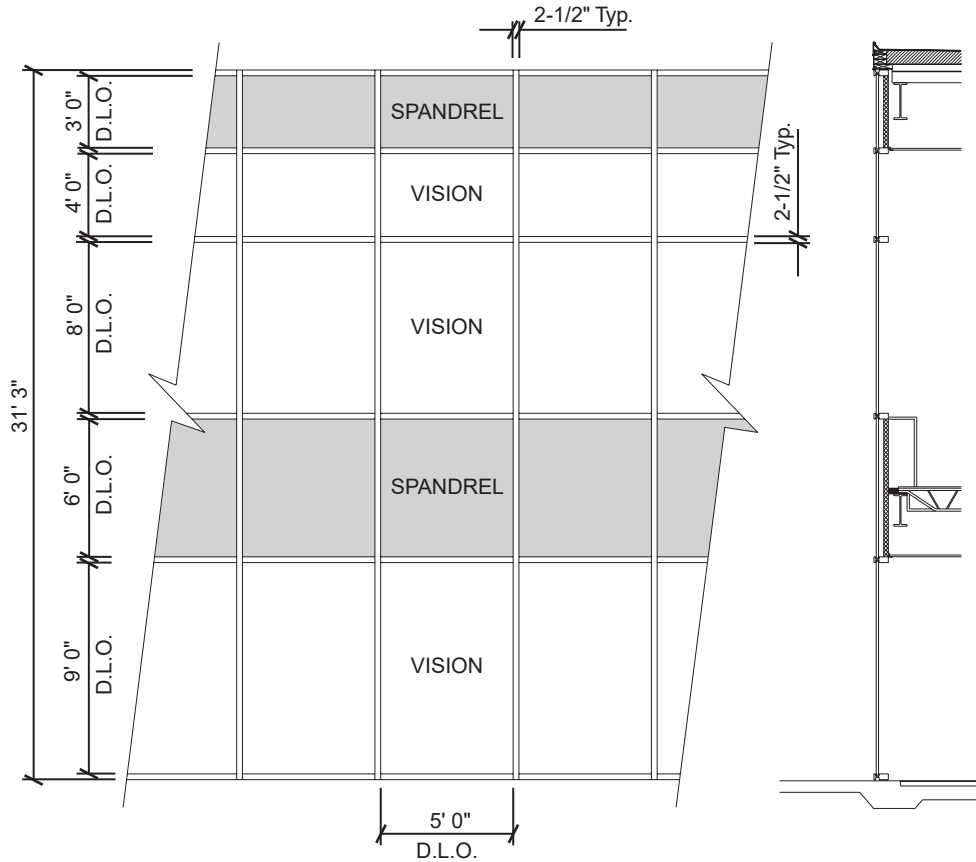

Vision Area

Example Glass U-factor	= 0.48 Btu/(ft ² · h · °F)
Vision Area	= 5(9 + 8 + 4) = 105.0 ft ²
Total Area (Vision)	= 5' 2-1/2" (9' 3-3/4" + 8' 2-1/2" + 4' 2-1/2") = 113.2 ft ²
Percentage of Vision Glass	= (Vision Area ÷ Total Area)100 = (105.0 ÷ 113.2)100 = 93%

Spandrel Area

Example Spandrel R-value	= 15 (ft ² · h · °F)/Btu
Spandrel Area	= 5(6 + 3) = 45.0 ft ²
Total Area (Spandrel)	= 5' 2-1/2" (6' 2-1/2" + 3' 3-3/4") = 49.6 ft ²
Percent of Spandrel	= (Spandrel Area ÷ Total Area)100 = (49.0 ÷ 49.6)100 = 91%

Laws and building and safety codes governing the design and use of Kawneer products, such as glazed entrance, window, and curtain wall products, vary widely. Kawneer does not control the selection of product configurations, operating hardware, or glazing materials, and assumes no responsibility therefor.

Kawneer reserves the right to change configuration without prior notice when deemed necessary for product improvement.

© 2013, Kawneer Company, Inc.

Vision Area Chart

System U-factor vs Percent of Vision Area

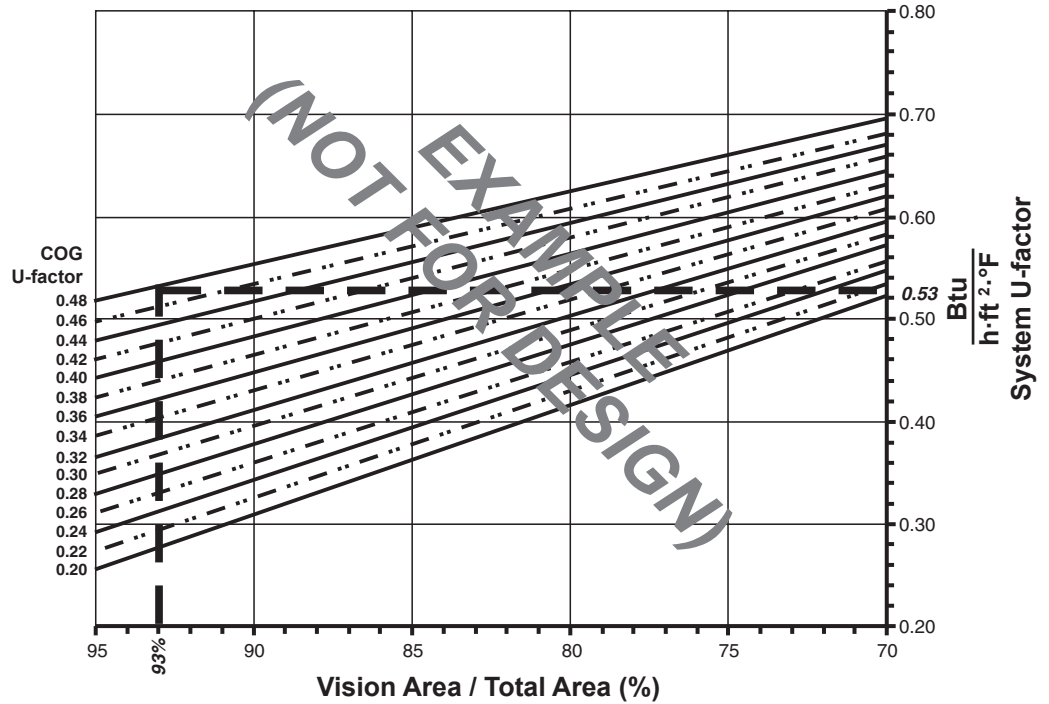

Based on a single curtain wall bay of 93% vision glass and center of glass U-factor of 0.48, System U-factor is equal to 0.53 Btu/(h·ft²·°F)

Spandrel Area Chart

System U-factor vs Percent of Spandrel Area

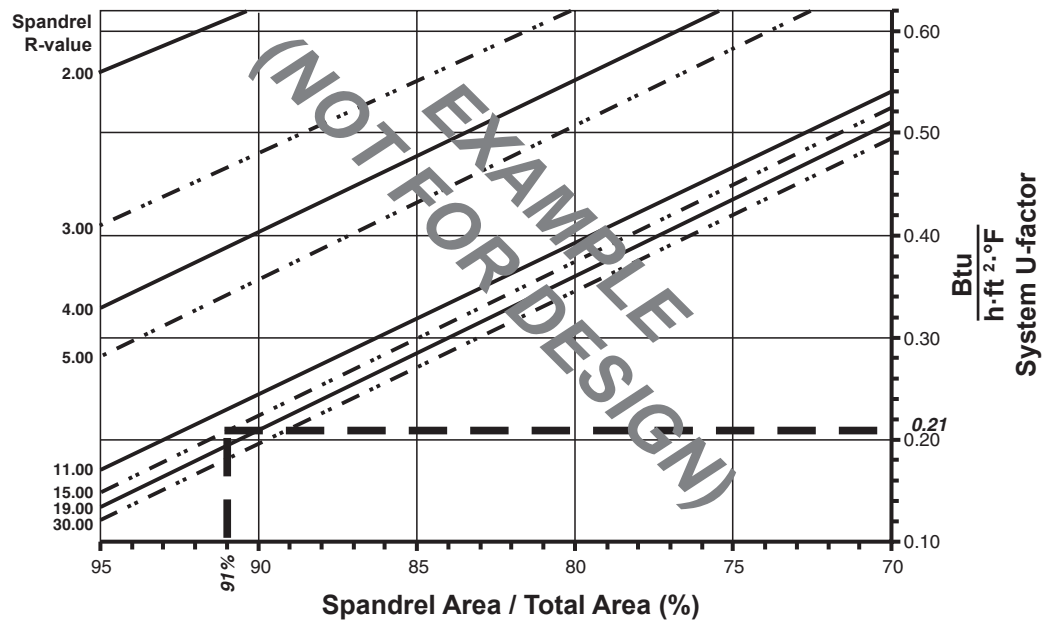

Based on a single curtain wall bay of 91% spandrel and center of spandrel R-value of 15, system U-factor is equal to 0.21 Btu/(h·ft²·°F)

Laws and building and safety codes governing the design and use of Kawneer products, such as glazed entrance, window, and curtain wall products, vary widely. Kawneer does not control the selection of product configurations, operating hardware, or glazing materials, and assumes no responsibility therefor.

Kawneer reserves the right to change configuration without prior notice when deemed necessary for product improvement.
© 2013, Kawneer Company, Inc.

Note:
 Values in parentheses are metric.
 COG=Center of Glass.
 Charts are generated per AAMA 507.

**4 Side Captured - Aluminum Pressure Plate
 1" Double Glazed - Aluminum Glazing Spacer**

System U-factor vs Percent of Glass Area

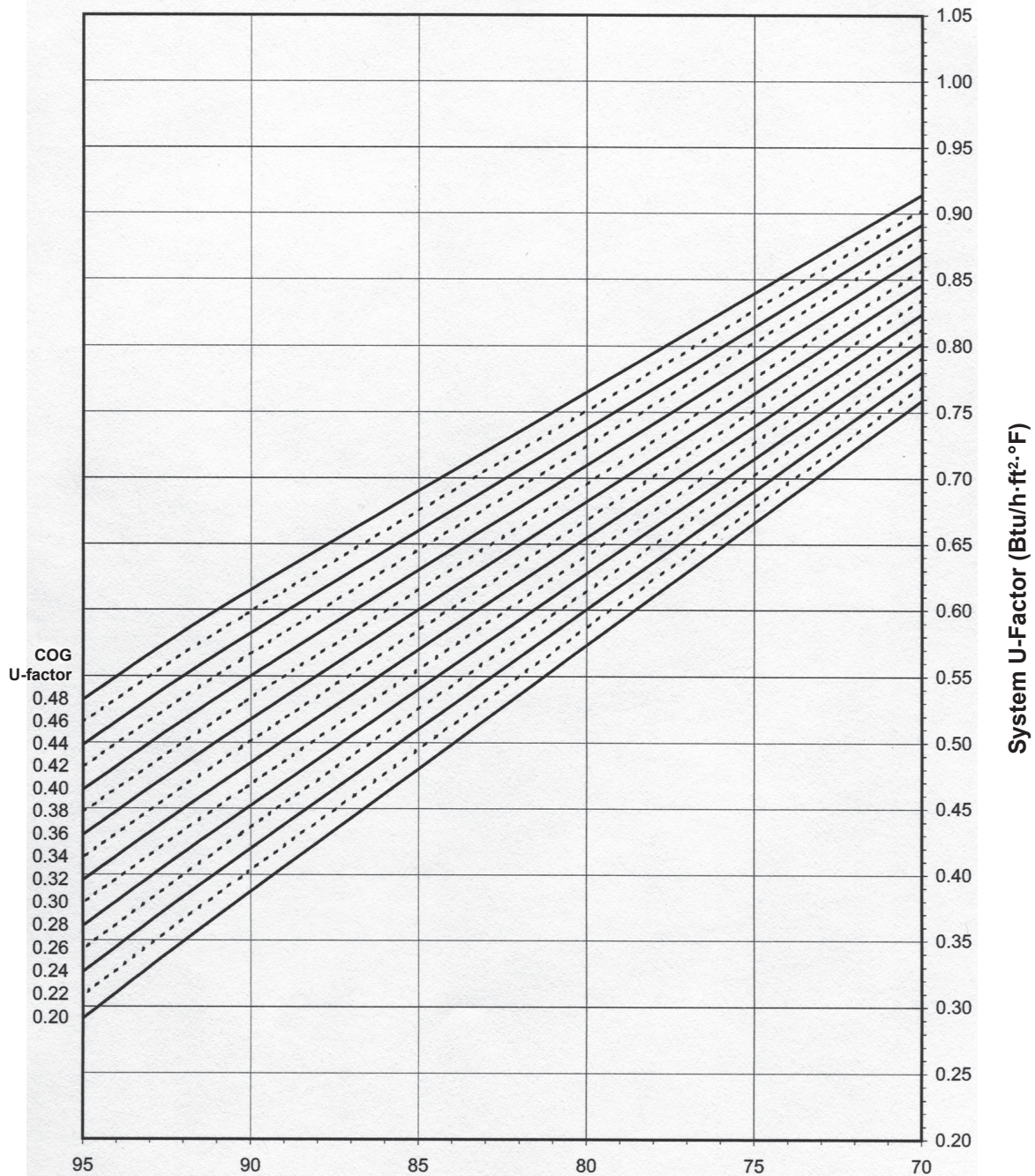

**Percent of Glass = Vision Area/Total Area
 (Total Daylight Opening/Projected Area)**

Notes for System U-factor, SHGC and VT charts:

For glass values that are not listed, linear interpolation is permitted.
 Glass properties are based on center of glass values and are obtained from your glass supplier.

Laws and building and safety codes governing the design and use of Kawneer products, such as glazed entrance, window, and curtain wall products, vary widely. Kawneer does not control the selection of product configurations, operating hardware, or glazing materials, and assumes no responsibility therefor.

Kawneer reserves the right to change configuration without prior notice when deemed necessary for product improvement.

© 2013, Kawneer Company, Inc.

4 Side Captured - Aluminum Pressure Plate
1" Double Glazed - Aluminum Glazing Spacer

System Solar Heat Gain Coefficient (SHGC) vs Percent of Vision Area

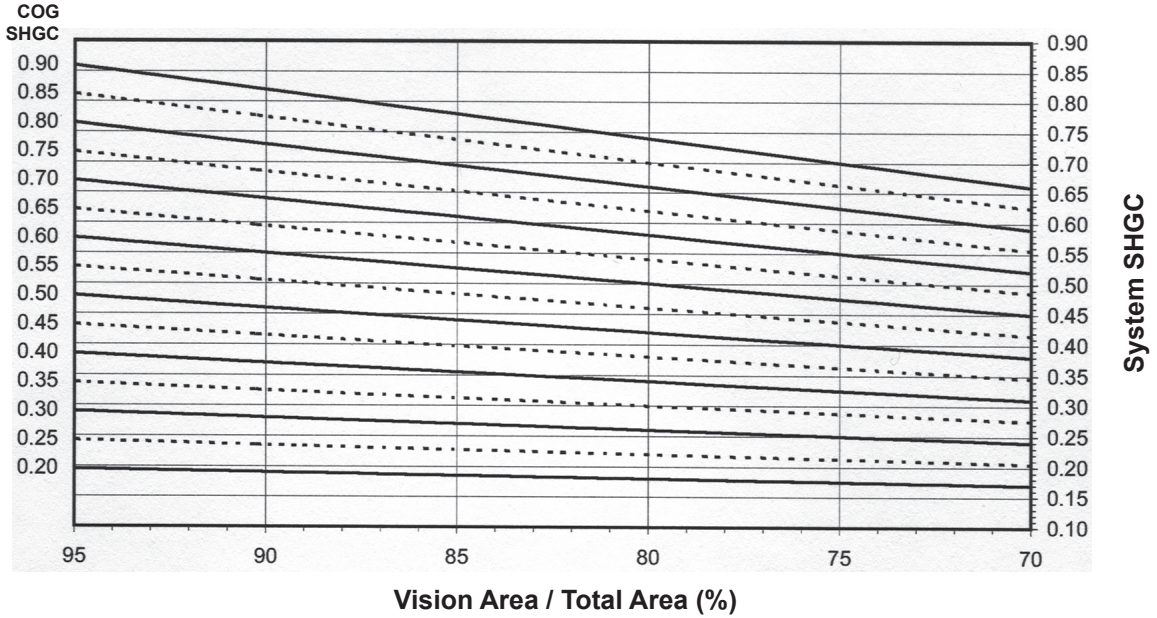

Charts are generated per AAMA 507.

System Visible Transmittance (VT) vs Percent of Vision Area

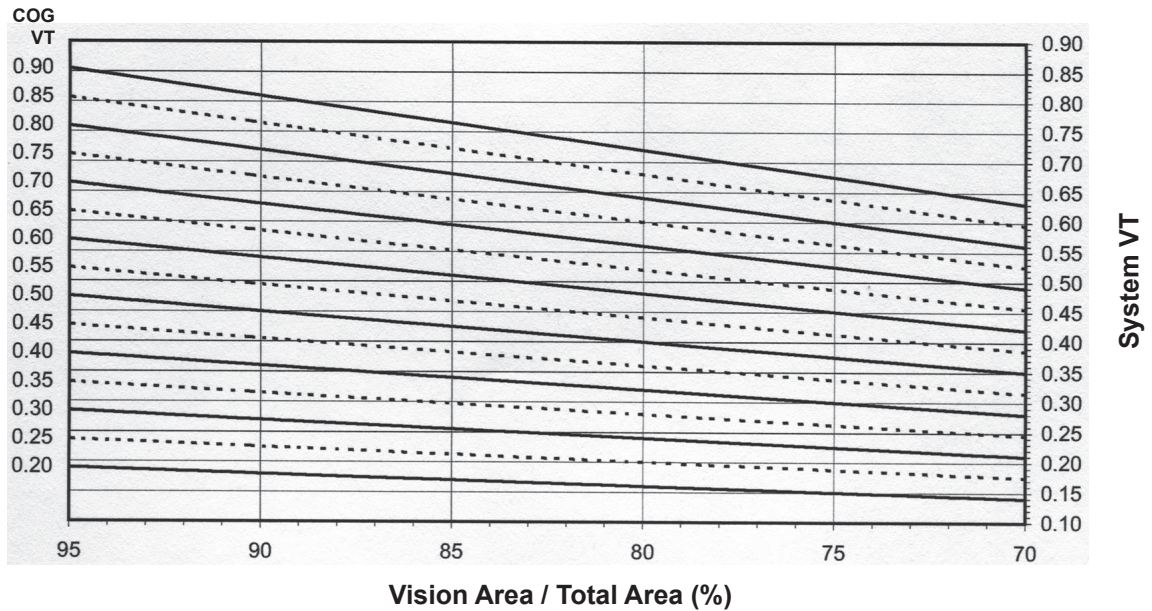

Charts are generated per AAMA 507.

Laws and building and safety codes governing the design and use of Kawneer products, such as glazed entrance, window, and curtain wall products, vary widely. Kawneer does not control the selection of product configurations, operating hardware, or glazing materials, and assumes no responsibility therefor.

Kawneer reserves the right to change configuration without prior notice when deemed necessary for product improvement.
© 2013, Kawneer Company, Inc.

Thermal Transmittance¹ (BTU/hr • ft² • °F)

Glass U-Factor ³	Overall U-Factor ⁴
0.48	0.61
0.46	0.59
0.44	0.58
0.42	0.56
0.40	0.55
0.38	0.53
0.36	0.51
0.34	0.50
0.32	0.48
0.30	0.46
0.28	0.45
0.26	0.43
0.24	0.41
0.22	0.40
0.20	0.38

**4 Side Captured
Aluminum Pressure Plate
1" Double Glazed
Aluminum Glazing Spacer**

NOTE: For glass values that are not listed, linear interpolation is permitted.

1. U-Factors are determined in accordance with NFRC 100.
2. SHGC and VT values are determined in accordance with NFRC 200.
3. Glass properties are based on center of glass values and are obtained from your glass supplier.
4. Overall U-Factor, SHGC, and VT Matricies are based on the standard NFRC specimen size of 2,000 mm wide by 2,000 mm high (78-3/4" by 78-3/4").

SHGC Matrix² (CAPTURED)

Glass SHGC ³	Overall SHGC ⁴
0.90	0.82
0.85	0.78
0.80	0.73
0.75	0.69
0.70	0.64
0.65	0.60
0.60	0.55
0.55	0.51
0.50	0.46
0.45	0.42
0.40	0.37
0.35	0.33
0.30	0.28
0.25	0.24
0.20	0.19

Visible Transmittance² (CAPTURED)

Glass VT ³	Overall VT ⁴
0.90	0.81
0.85	0.77
0.80	0.72
0.75	0.68
0.70	0.63
0.65	0.59
0.60	0.54
0.55	0.50
0.50	0.45
0.45	0.41
0.40	0.36
0.35	0.32
0.30	0.27
0.25	0.23
0.20	0.18

Laws and building and safety codes governing the design and use of Kawneer products, such as glazed entrance, window, and curtain wall products, vary widely. Kawneer does not control the selection of product configurations, operating hardware, or glazing materials, and assumes no responsibility therefor.

Kawneer reserves the right to change configuration without prior notice when deemed necessary for product improvement.
© 2013, Kawneer Company, Inc.

Note:
 Values in parentheses are metric.
 COG=Center of Glass.
 Charts are generated per AAMA 507.

**SSG - Aluminum Pressure Plate
 1" Double Glazed - Aluminum Glazing Spacer**

System U-factor vs Percentage of Glass Area

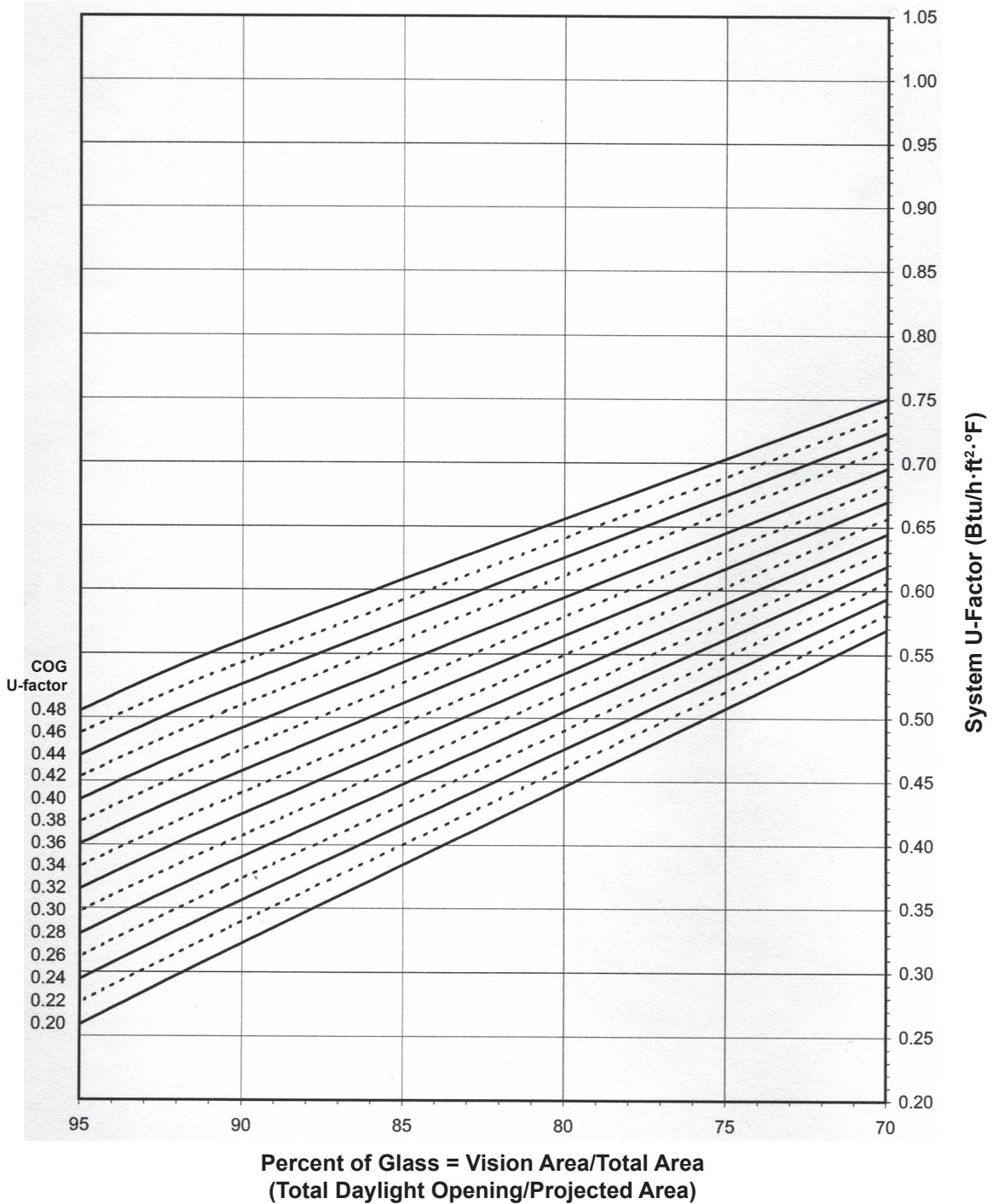

Notes for System U-factor, SHGC and VT charts:

For glass values that are not listed, linear interpolation is permitted.
 Glass properties are based on center of glass values and are obtained from your glass supplier.

Laws and building and safety codes governing the design and use of Kawneer products, such as glazed entrance, window, and curtain wall products, vary widely. Kawneer does not control the selection of product configurations, operating hardware, or glazing materials, and assumes no responsibility therefor.

Kawneer reserves the right to change configuration without prior notice when deemed necessary for product improvement.
 © 2013, Kawneer Company, Inc.

**SSG - Aluminum Pressure Plate
1" Double Glazed - Aluminum Glazing Spacer**
System Solar Heat Gain Coefficient (SHGC) vs Percent of Vision Area

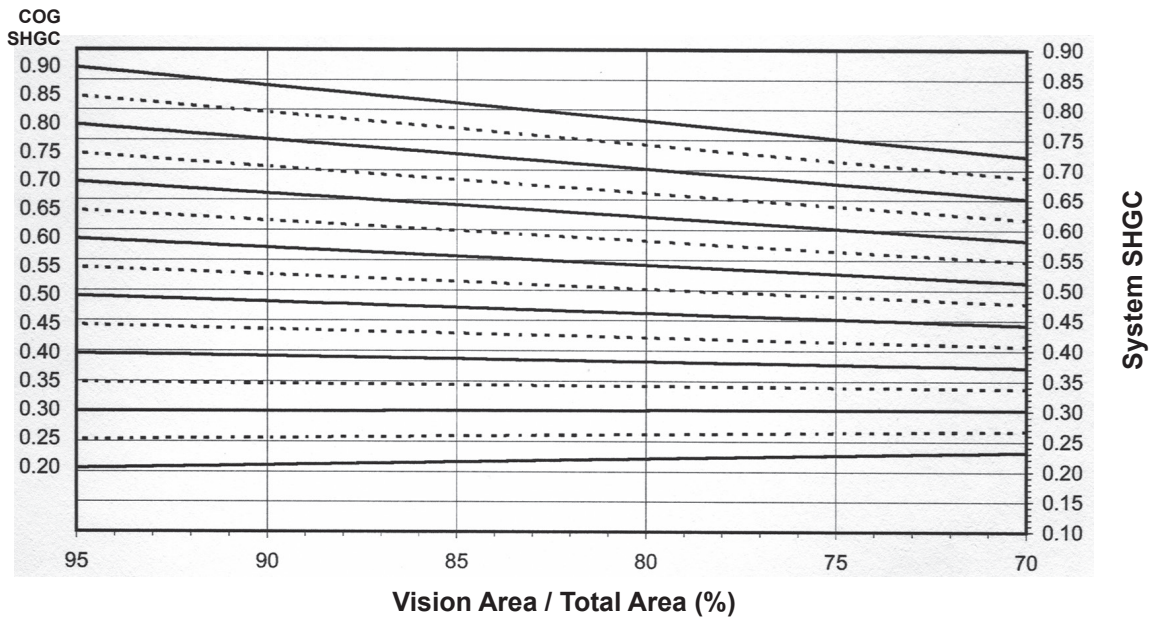

Charts are generated per AAMA 507.

System Visible Transmittance (VT) vs Percent of Vision Area

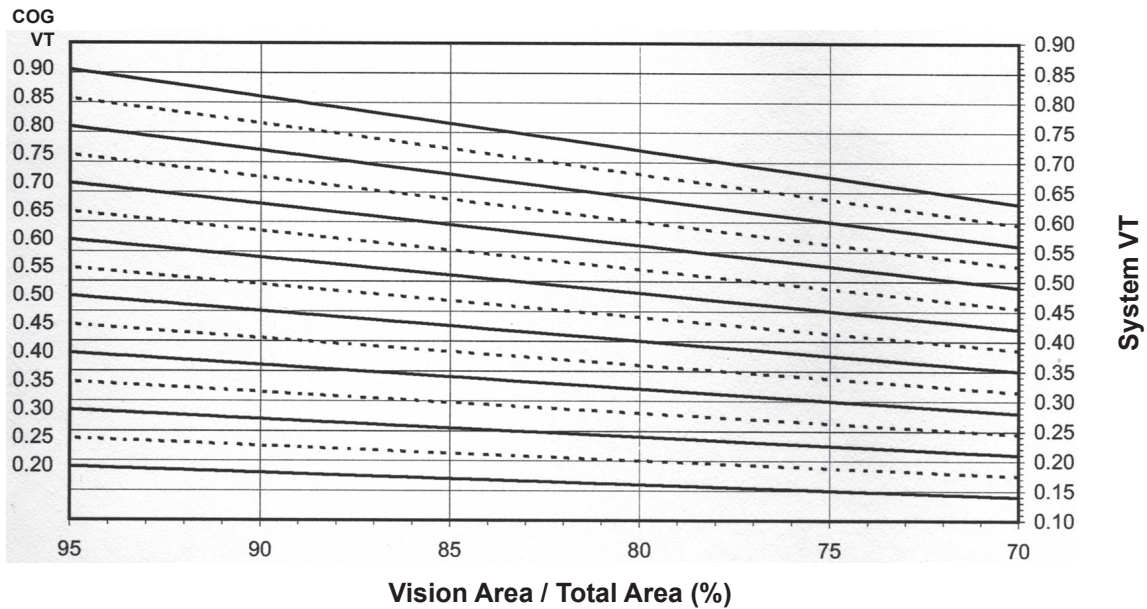

Charts are generated per AAMA 507.

System SHGC

System VT

Laws and building and safety codes governing the design and use of Kawneer products, such as glazed entrance, window, and curtain wall products, vary widely. Kawneer does not control the selection of product configurations, operating hardware, or glazing materials, and assumes no responsibility therefor.

Kawneer reserves the right to change configuration without prior notice when deemed necessary for product improvement.
© 2013, Kawneer Company, Inc.

Thermal Transmittance ¹ (BTU/hr • ft ² • °F)

Glass U-Factor ³	Overall U-Factor ⁴
0.48	0.55
0.46	0.54
0.44	0.52
0.42	0.50
0.40	0.49
0.38	0.47
0.36	0.45
0.34	0.43
0.32	0.42
0.30	0.40
0.28	0.38
0.26	0.37
0.24	0.35
0.22	0.33
0.20	0.32

**SSG
Aluminum Pressure Plate
1" Double Glazed
Aluminum Glazing Spacer**

NOTE: For glass values that are not listed, linear interpolation is permitted.

1. U-Factors are determined in accordance with NFRC 100.
2. SHGC and VT values are determined in accordance with NFRC 200.
3. Glass properties are based on center of glass values and are obtained from your glass supplier.
4. Overall U-Factor, SHGC, and VT Matricies are based on the standard NFRC specimen size of 2,000 mm wide by 2,000 mm high (78-3/4" by 78-3/4").

SHGC Matrix ² (SSG)

Glass SHGC ³	Overall SHGC ⁴
0.90	0.84
0.85	0.80
0.80	0.75
0.75	0.71
0.70	0.66
0.65	0.62
0.60	0.57
0.55	0.53
0.50	0.48
0.45	0.44
0.40	0.39
0.35	0.35
0.30	0.30
0.25	0.26
0.20	0.21

Visible Transmittance ² (SSG)

Glass VT ³	Overall VT ⁴
0.90	0.81
0.85	0.77
0.80	0.72
0.75	0.68
0.70	0.63
0.65	0.59
0.60	0.54
0.55	0.50
0.50	0.45
0.45	0.41
0.40	0.36
0.35	0.32
0.30	0.27
0.25	0.23
0.20	0.18

Laws and building and safety codes governing the design and use of Kawneer products, such as glazed entrance, window, and curtain wall products, vary widely. Kawneer does not control the selection of product configurations, operating hardware, or glazing materials, and assumes no responsibility therefor.

Kawneer reserves the right to change configuration without prior notice when deemed necessary for product improvement.
© 2013, Kawneer Company, Inc.

CONDENSATION RESISTANCE

Glazing Infill	Pressure Plate Type	Condensation Resistance Factor (CRF) AAMA 1503		Temperature Index (TI) CSA A440-0	
		Frame	Glass	Frame	Glass
1" Double Captured	Aluminum	69	57	---	---
1" Double 2-Sided SSG	Aluminum	73	60	---	---

Laws and building and safety codes governing the design and use of Kawneer products, such as glazed entrance, window, and curtain wall products, vary widely. Kawneer does not control the selection of product configurations, operating hardware, or glazing materials, and assumes no responsibility therefor.

Kawneer reserves the right to change configuration without prior notice when deemed necessary for product improvement.
© 2013, Kawneer Company, Inc.